

SMARTER WATER FOR A
SMARTER HOME

02

POOL FILTERS



SUPER SERIES SAND FILTER

Made of high density polyethylene material and integration of blow molding technology. HDPE filter tank is compatible with many different weather condition. Unique structural design gets the best clarity of filtered water and a better backwash.



SDG-17~SDG-26



SCG-20~SCG-26

Advantages:

- More efficient: 30% more of filtration bed improves the filtration quality easily.
- Environmental, safe & corrosive-proof material: suitable to all types of swimming pools.
- Easy maintenance: no tools is required for maintenance or operation.

- Pool in need of better water clarity.
- Professional approach of getting better water.

Features:

- Suitable for pools with different disinfection system such as salt chlorine generator, UV sterilizer, Ozone system and chemical dosing.
- Can be used for Pool, Spa and Water features.
- Easy to maintain and replace.

1 Inlet/outlet can meet with metric/imperial pipe, more convenient to operate.

2 One-piece plastic clamp allows 360 rotation of valve to simplify installation.

3 More volume of filtration bed gets better clarity of filtered water & less backwash.

4 High density polyethylene filter tank material manufactured to maximize the strength of the filter.

5 Unique double-layered lateral enhances filtration efficiency and allows complete backwash.

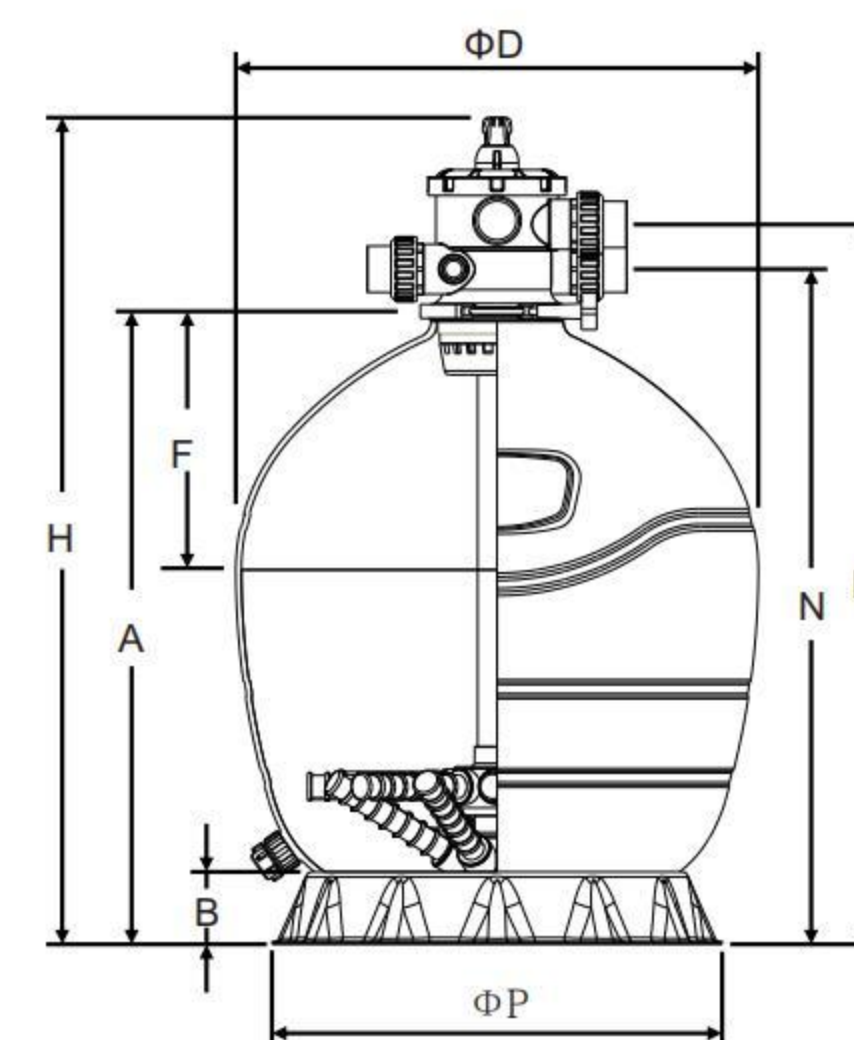

Model	WL-SDG-17	WL-SDG-20	WL-SDG-24	WL-SDG-26
ΦD(mm)	425	500	600	650
H(mm)	767	890	983	1028
B(mm)	75	75	75	90
A(mm)	526	650	743	787
ΦP(mm)	390	390	390	560
N(mm)	579	702	795	839
M(mm)	635	758	850	895
F(mm)	195	236	285	319

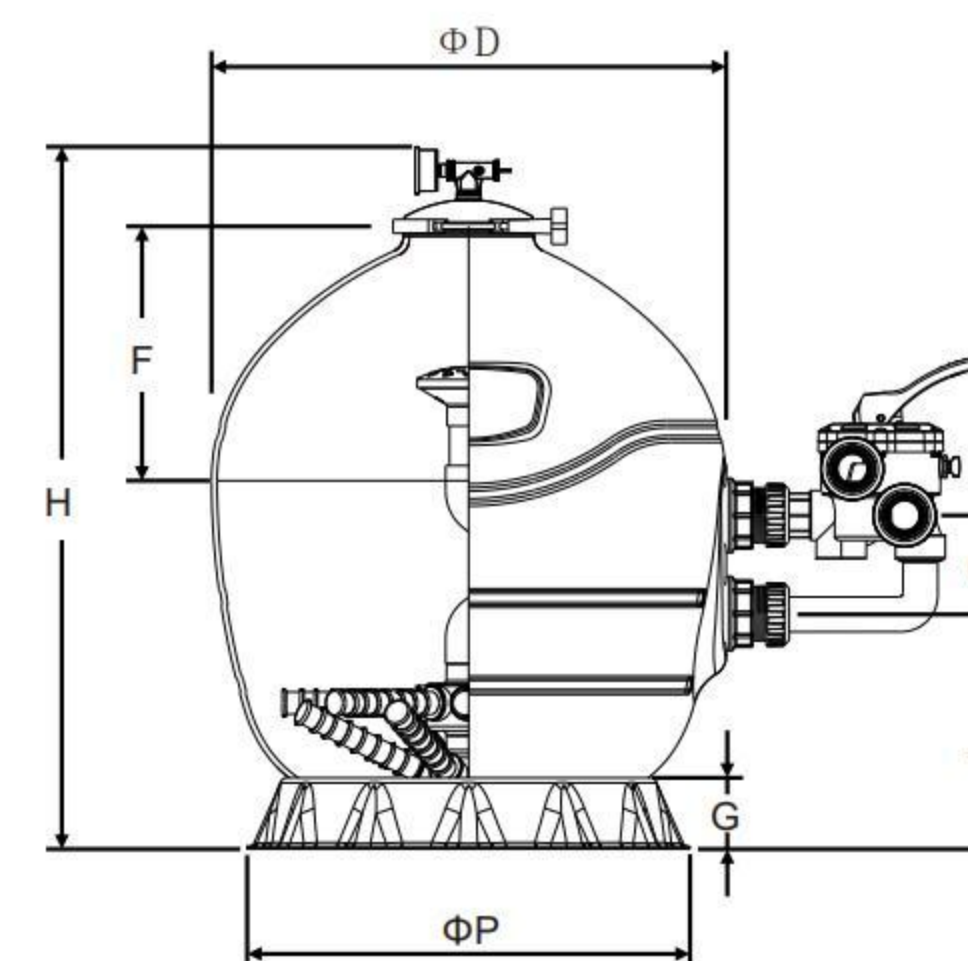

Model	WL-SCG-20	WL-SCG-24	WL-SCG-26
ΦD(mm)	500	600	650
H(mm)	736	830	887
A(mm)	241	310	296
ΦP(mm)	390	390	560
C(mm)	125	125	125
G(mm)	75	75	90
F(mm)	236	285	319

Product parameters

Model	Pipe Size		Filter Area (m ²)	Design Flow		0.5-0.8mm Sand Weight (kg)	Tank Volume (m ³)	Valve Volume (m ³)	Tank Weight (kg)	Valve Weight (kg)
	inches	mm		m ³ /h	lpm					
SDG-17	1.5	50	0.14	7.0	117	50	0.11	0.02	9.8	3
SDG-20	1.5	50	0.19	9.5	158	90	0.16	0.02	12.3	3
SDG-24	1.5	50	0.27	13.5	225	140	0.26	0.02	15.2	3
SDG-26	1.5	50	0.32	16.0	267	170	0.34	0.02	18	3

Note: The model WL-SDG-17 is with one layer lateral.

Model	Pipe Size		Filter Area (m ²)	Design Flow		0.5-0.8mm Sand Weight (kg)	Tank Volume (m ³)	Valve Volume (m ³)	Tank Weight (kg)	Valve Weight (kg)
	inches	mm		m ³ /h	lpm					
SCG-20	1.5	50	0.19	9.5	158	90	0.16	0.02	13.3	3
SCG-24	1.5	50	0.27	13.5	225	140	0.26	0.02	16.2	3
SCG-26	1.5	50	0.32	16.0	267	170	0.34	0.02	19	3

MAXIMUM WORKING PRESSURE:40psi/2.8kg/cm²
MAXIMUM TEMPERATURE≤50 °C

"P-DG" SERIES FILTERS

POOL FILTERS

Features:

- Made of high density polyethylene material, corrosive-proof, safe and environmental.
- Unitized thermal plastic filter tank tough, durable and suitable for many different weather condition.
- Easy-to-use multiport valve lets you select any of the valve/filter operation with a simple lever-action.
- Clamp lock is designed to allow 360 degree rotation to simplify installation.
- Compact and save space.
- These sand filters are applicable in all types of pool, spa, fountain, waterscape and aquarium.



Main parts:

- Easy-to-use six-position valve makes the selection of the valve/ filter simple.
 - * FILTER (Normal filtration and vacuuming).
 - * BACKWASH (Clean filter by reversing the flow).
 - * RINSE (Used after backwash to flush dirt from valve).
 - * WASTE (By-passes filter, used for vacuuming to waste or lowering water level).
 - * RECIRCULATE (By-passes filter for circulation water to pool).
 - * CLOSE.
- Unitized and durable tank.
- Special drainage design, easy to drain, maintain and ice-free in winter.

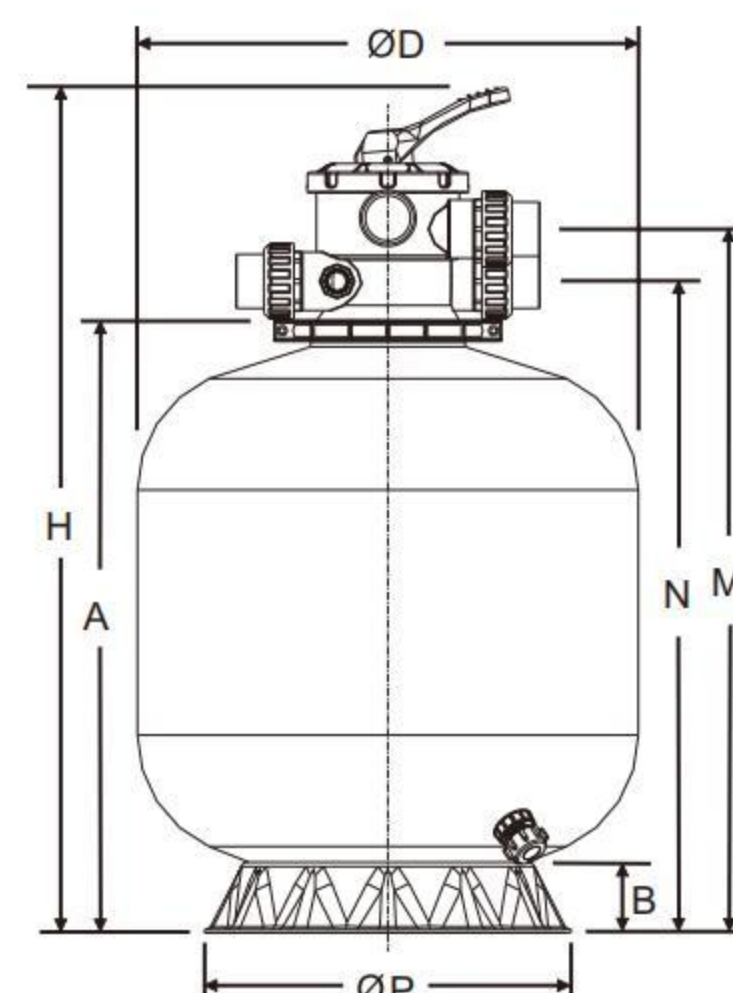

φD(mm)	350	410	450	535	635	710
H(mm)	750	770	830	870	970	1040
B(mm)	75	75	75	75	95	95
A(mm)	490	510	570	610	710	780
φP(mm)	319	319	390	390	565	565
N(mm)	545	565	625	665	765	835
M(mm)	600	620	680	720	820	890

Model	Pipe Size		Filter Area (m ²)	Design Flow		0.5-0.8mm Sand Weight (kg)	Tank Volume (m ³)	Valve Volume (m ³)	Tank Weight (kg)	Valve Weight (kg)
	inches	mm		m ³ /h	lpm					
P-DG350	1.5	50	0.10	4.50	75	25	0.06	0.02	4.0	3
P-DG400	1.5	50	0.13	6.50	108	34	0.09	0.02	5.0	3
P-DG450	1.5	50	0.16	8.00	133	50	0.15	0.02	6.5	3
P-DG500	1.5	50	0.23	11.50	192	80	0.20	0.02	9.2	3
P-DG650	1.5	50	0.32	16.00	267	160	0.32	0.02	12.1	3
P-DG700	1.5	50	0.40	20.00	333	220	0.42	0.02	17.0	3

MAXIMUM WORKING PRESSURE: 36psi/2.5kg/cm²(PLASTIC CLAMP)

MAXIMUM WORKING WATER TEMPERATURE≤43°C

"P-CG" SERIES FILTERS

POOL FILTERS

Features:

- Made of high density polyethylene material, corrosive-proof, safe and environmental.
- Unitized thermal plastic filter tank, tough, durable and suitable for many different weather condition.
- East-to-use multiport valve lets you select any of the valve/filter operation with a simple lever-action.
- Compact and save space.
- Top diffuser ensures even distribution of water over the top of the sand bed.
- These sand filters are applicable in all types of pool, spa, fountain waterscape and aquarium.



Main parts:

- Easy-to-use six-position valve makes the selection of the valve/ filter simple.
 - * FILTER (Normal filtration and vacuuming).
 - * BACKWASH (Clean filter by reversing the flow).
 - * RINSE (Used after backwash to flush dirt from valve).
 - * WASTE (By-passes filter, used for vacuuming to waste or lowering water level).
 - * RECIRCULATION (By-passes filter for circulation water to pool).
 - * CLOSE.
- Unitized and durable tank.
- Special drainage design, easy to drain, maintain and ice-free in winter.
- Pressure gauge makes it easier to examine and maintain.
- Air relief bolt enables easy release of trapped air during operation of the filter.

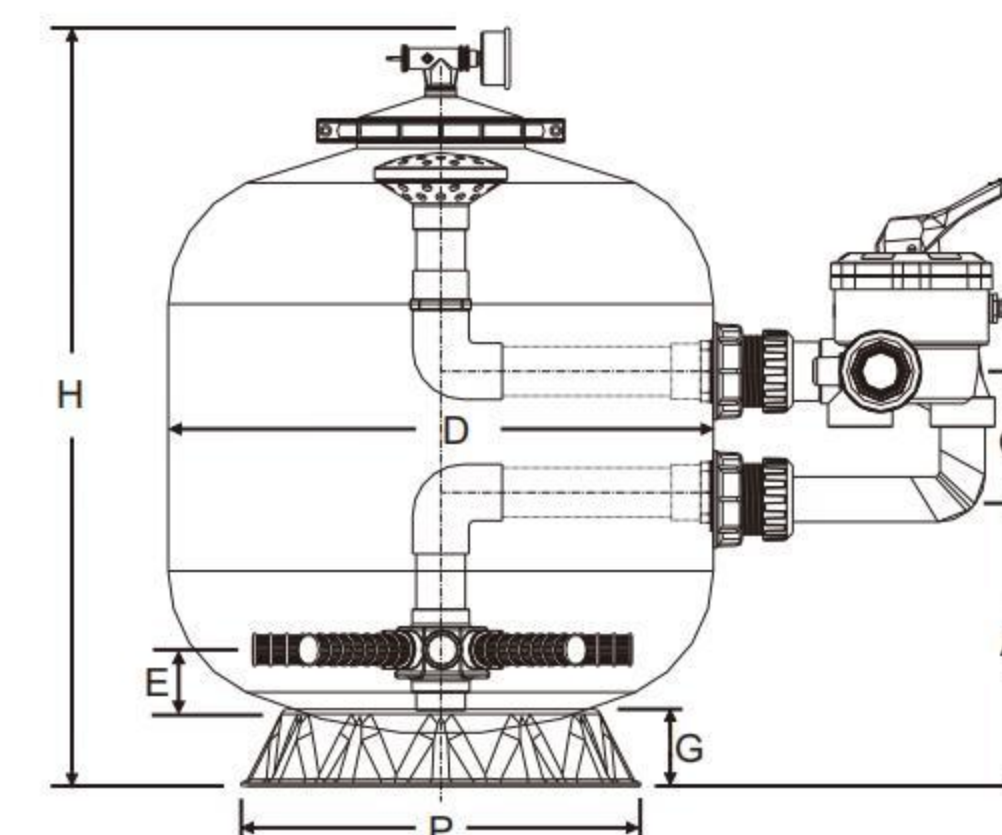

φD(mm)	450	535	635	710
H(mm)	670	710	810	880
A(mm)	260	290	310	360
φP(mm)	390	390	565	565
C(mm)	125	125	125	125
G(mm)	75	75	95	90
E(mm)	90	90	90	95

Model	Pipe Size		Filter Area (m ²)	Design Flow		0.5-0.8mm Sand Weight (kg)	Tank Volume (m ³)	Valve Volume (m ³)	Tank Weight (kg)	Valve Weight (kg)
	inches	mm		m ³ /h	lpm					
P-CG450	1.5	50	0.16	8.00	133	50	0.15	0.02	7.0	3
P-CG500	1.5	50	0.23	11.50	192	80	0.20	0.02	10.2	3
P-CG650	1.5	50	0.32	16.00	267	160	0.32	0.02	13.1	3
P-CG700	1.5	50	0.40	20.00	333	220	0.42	0.02	18.0	3

MAXIMUM WORKING PRESSURE: 36psi/2.5kg/cm²(PLASTIC CLAMP)

MAXIMUM OPERATING WATER TEMPERATURE≤43°C

"ADG" SERIES FILTERS

Top mount sand vertical filters are built to be tougher, longer lasting and better performing. Constructed of polyester resin and non-corrosive extra-thick fiberglass filament winding, all internal components and connections are injection molded PVC. UV-resistance surface allows working under sunshine.

Easy-to-use six-position valve makes you select any of the valve/filter operation in a proper way.



- FILTER (Normal filtration and vacuuming).
- BACKWASH (Clean filter by reversing the flow).
- RINSE (Used after backwash to flush dirt from valve).
- WASTE (By-passes filter, used for vacuuming to waste or lowering water level).
- RECIRCULATE (By-passes filter for circulating water to pool).
- CLOSE .

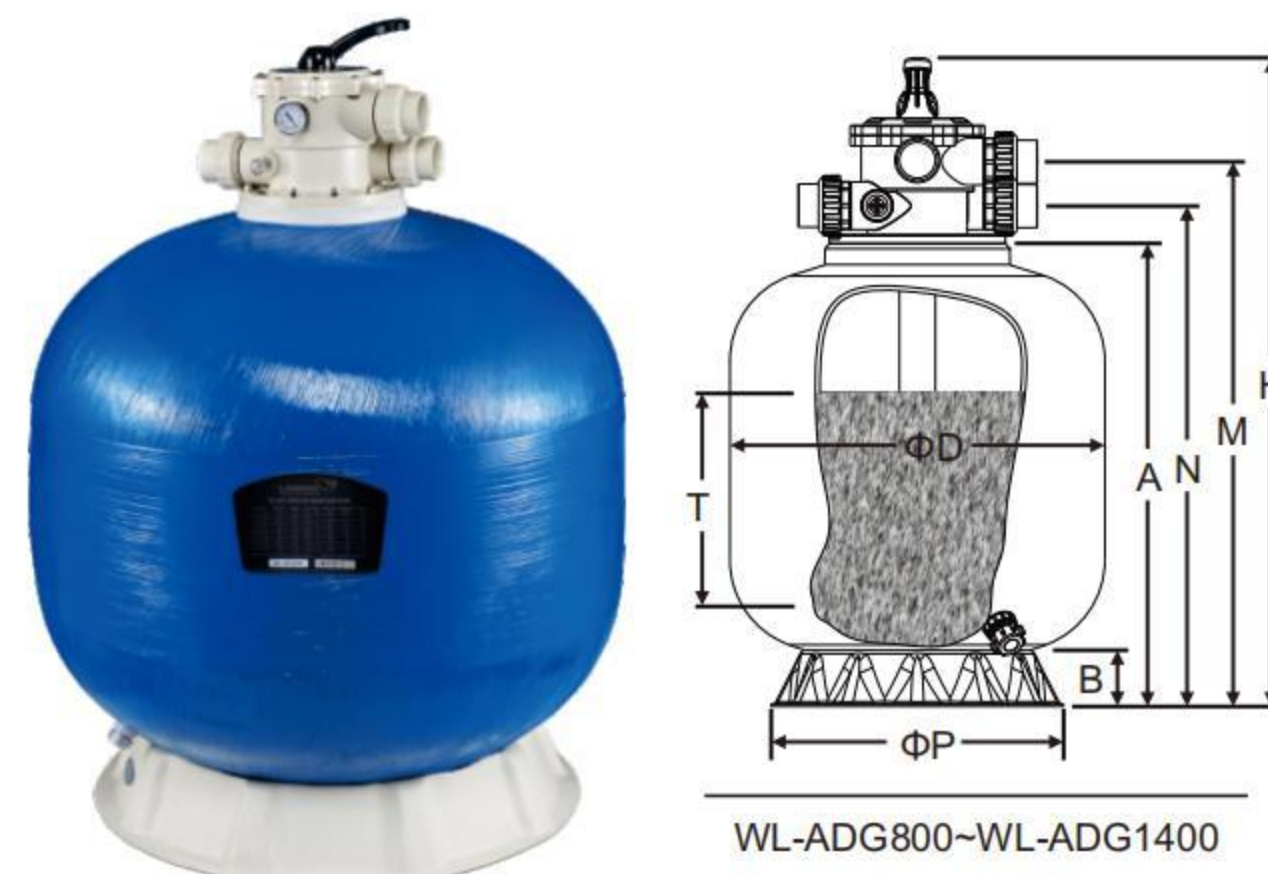

ΦD(mm)	350	410	450	535	635	710	750	800	900	1000	1100	1200	1400
H(mm)	750	770	830	870	970	1040	1120	1130	1270	1340	1460	1540	1750
A(mm)	490	510	570	610	710	780	820	830	970	1040	1160	1240	1450
B(mm)	75	75	75	75	95	95	95	150	150	150	180	180	180
M(mm)	600	620	680	720	820	890	962	973	1112	1182	1302	1392	1592
N(mm)	545	565	625	665	765	835	882	892	1032	1102	1222	1312	1512
ΦP(mm)	319	319	390	390	565	565	565	790	790	790	1010	1010	1010
T(mm)	150	160	220	260	370	450	490	490	500	520	570	650	850

Model	Pipe Size		Filter Area (m ²)	Design Flow		0.5-0.8mm Sand Weight (kg)	Tank Volume (m ³)	Valve Volume (m ³)	Tank Diameter (mm)	Tank Height (mm)
	inches	mm		m ³ /h	lpm					
WL-ADG350	1.5	50	0.10	4.5	75	25	0.06	0.02	350	750
WL-ADG400	1.5	50	0.13	6.5	108	34	0.09	0.02	410	770
WL-ADG450	1.5	50	0.16	8.0	133	50	0.15	0.02	450	830
WL-ADG500	1.5	50	0.23	11.5	192	80	0.20	0.02	535	870
WL-ADG650	1.5	50	0.32	16.0	267	160	0.32	0.02	635	970
WL-ADG700	1.5	50	0.40	20.0	333	220	0.42	0.02	710	1040
WL-ADG750	2.0	63	0.44	22.0	367	230	0.44	0.03	750	1120
WL-ADG800	2.0	63	0.50	25.0	417	260	0.68	0.03	800	1130
WL-ADG900	2.0	63	0.64	30.0	533	400	0.95	0.03	900	1270
WL-ADG1000	2.0	63	0.79	35.0	645	600	1.29	0.03	1000	1340
WL-ADG1100	2.0	63	0.95	44.0	716	800	1.40	0.03	1100	1460
WL-ADG1200	2.0	63	1.13	50.0	850	920	2.26	0.03	1200	1540
WL-ADG1400	2.0	63	1.53	68.0	1133	1400	3.50	0.03	1400	1750

STANDARD: MAXIMUM WORKING PRESSURE: 36psi/2.5kg/cm² MAXIMUM OPERATING WATER TEMPERATURE≤50°C MAXIMUM TESTING PRESSURE:58psi/4.0kg/cm²
OPTIONAL: MAXIMUM WORKING PRESSURE: 58psi/4.0kg/cm²(WL-ADG800-1400) MAXIMUM OPERATING WATER TEMPERATURE≤50°C MAXIMUM TESTING PRESSURE:86psi/6.0kg/cm²

"BCG" SERIES FILTERS

Side mount sand filters are built to be tougher, longer lasting and better performing. Constructed of polyester resin and non-corrosive fiberglass filament winding, all internal components and connections are injection molded PVC. They produce more filtered water with less pump horsepower. UV-resistance surface allows working under sunshine. Easy-to-use six-position valve makes you select any of the valve/filter operation in a proper way.

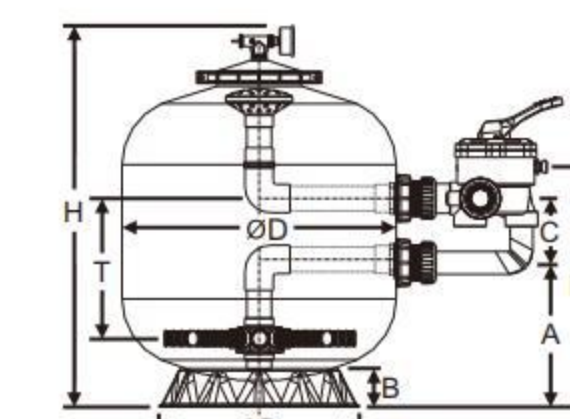

WL-BCG450~WL-BCG700



WL-BCG800~WL-BCG1200

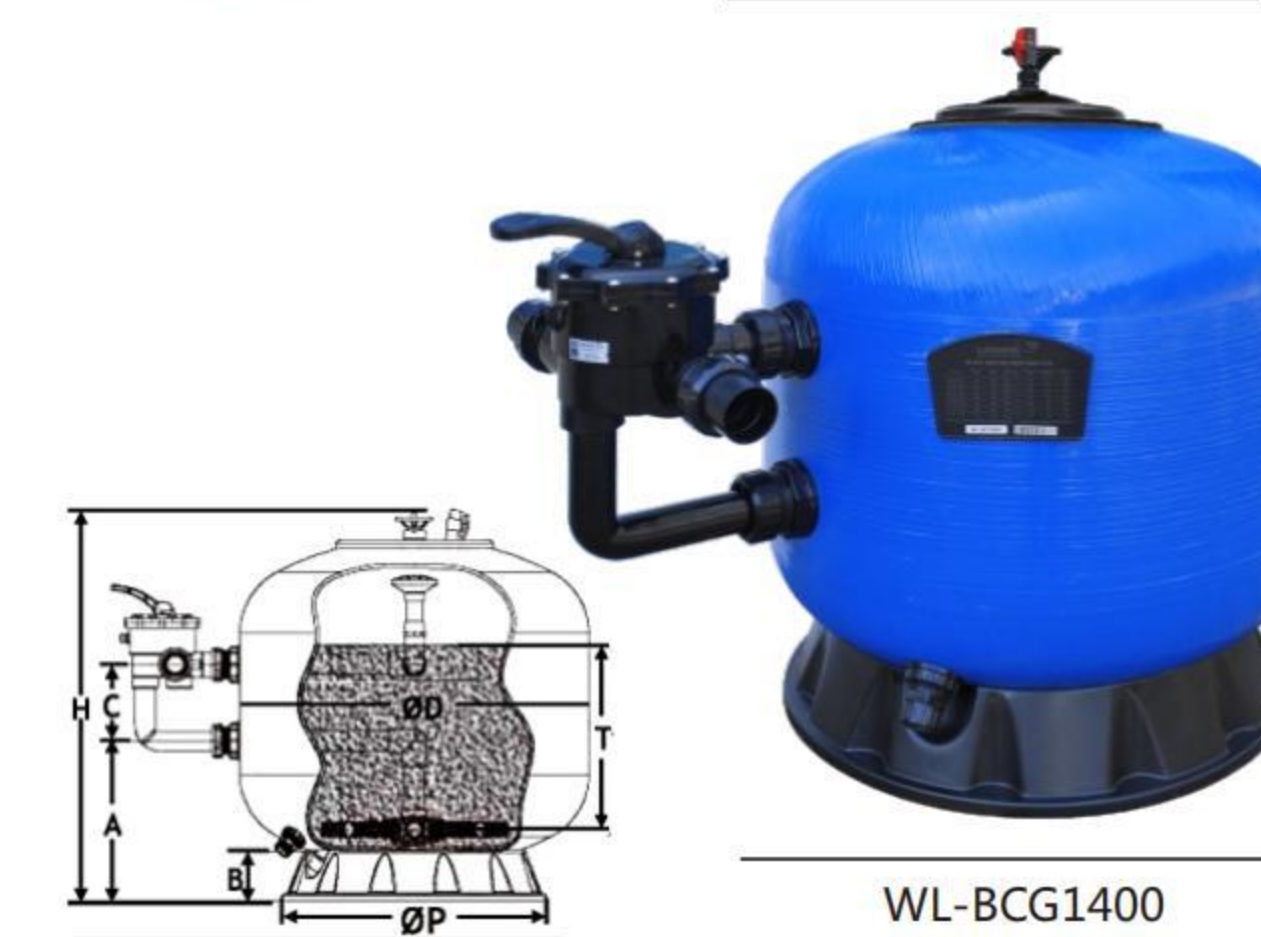

WL-BCG1400

ΦD(mm)	450	535	635	710	750	800	900	1000	1100	1200	1400
H(mm)	670	710	810	880	980	1010	1100	1160	1260	1340	1570
A(mm)	260	290	310	360	385	385	430	540	540	540	700
B(mm)	75	75	95	90	120	150	150	150	180	180	180
C(mm)	125	125	125	125	220	220	220	220	220	220	220
M(mm)	440	460	490	540	680	680	725	835	835	835	---
ΦP(mm)	390	390	565	565	565	790	790	790	1010	1010	1010
T(mm)	250	280	300	350	400	420	480	510	560	600	630

Model	Pipe Size		Filter Area (m ²)	Design Flow		0.5-0.8mm Sand Weight (kg)	Tank Volume (m ³)	Valve Volume (m ³)	Tank Diameter (mm)	Tank Height (mm)
	inches	mm		m ³ /h	lpm					
WL-BCG450	1.5	50	0.16	8.0	133	50	0.15	0.02	450	670
WL-BCG500	1.5	50	0.23	11.5	192	80	0.20	0.02	535	710
WL-BCG650	1.5	50	0.32	16.0	267	160	0.32	0.02	635	810
WL-BCG700	1.5	50	0.40	20.0	333	220	0.42	0.02	710	880
WL-BCG750	2.0	63	0.44	22.0	367	230	0.44	0.02	750	980
WL-BCG800	2.0	63	0.50	25.0	417	260	0.68	0.02	800	1010
WL-BCG900	2.0	63	0.64	30.0	533	400	0.92	0.02	900	1100
WL-BCG1000	2.0	63	0.79	35.0	645	600	1.48	0.02	1000	1160
WL-BCG1100	2.0	63	0.95	44.0	716	800	1.98	0.02	1100	1260
WL-BCG1200	2.0	63	1.13	50.0	850	920	2.42	0.02	1200	1340
WL-BCG1400	2.0	63	1.53	68.0	1133	1400	3.26	0.02	1400	1570

STANDARD: MAXIMUM WORKING PRESSURE: 36psi/2.5kg/cm² MAXIMUM OPERATING WATER TEMPERATURE≤50°C MAXIMUM TESTING PRESSURE:58psi/4.0kg/cm²
OPTIONAL: MAXIMUM WORKING PRESSURE: 58psi/4.0kg/cm²(WL-BCG800-1400) MAXIMUM OPERATING WATER TEMPERATURE≤50°C MAXIMUM TESTING PRESSURE:86psi/6.0kg/cm²

LAMINATED SAND FILTERS

- Made of fibreglass reinforce laminated polyester.
- Smooth and high brightness appearance.
- 6-way multiport valve.
- Sight glass for inspection of filtered water.
- Easy maintenance, easy cleaning.
- Maximum Working Pressure:36psi/2.5kg/cm².
- Maximum temperature:50°C.



WL-ICG450~WL-ICG900



WL-IDG400~WL-IDG900

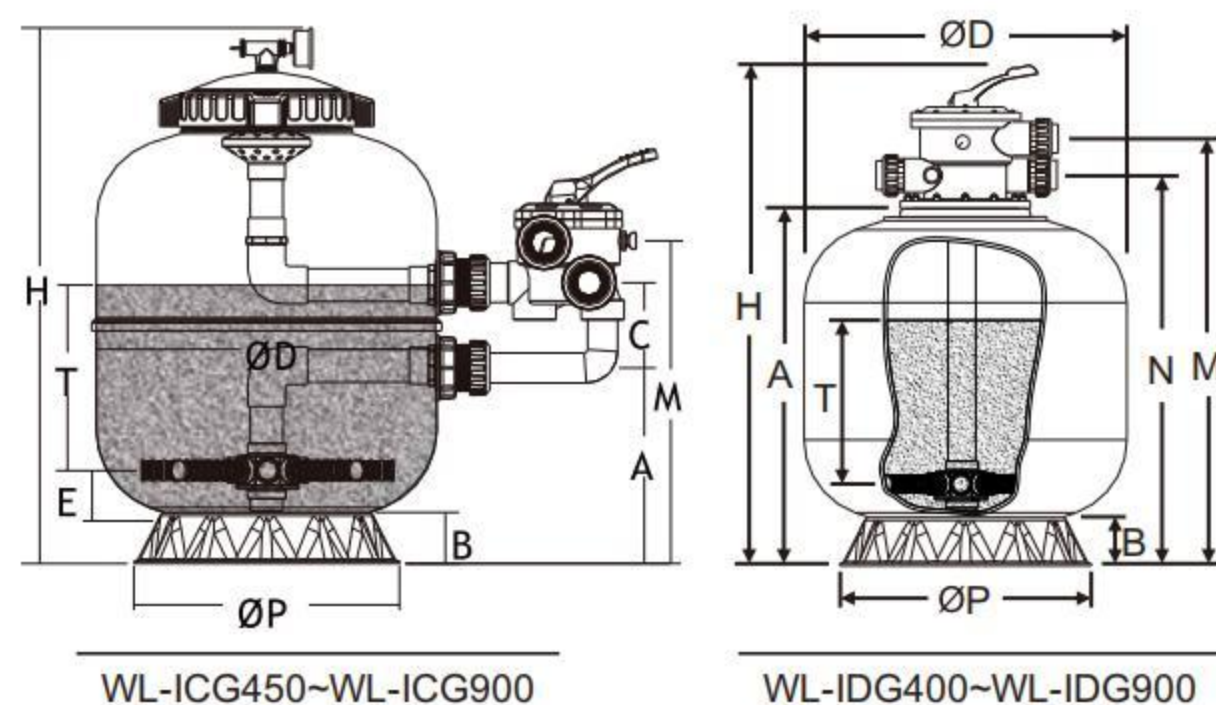

WL-ICG450~WL-ICG900

WL-IDG400~WL-IDG900

Model	WL-ICG450	WL-ICG500	WL-ICG650	WL-ICG700	WL-ICG800	WL-ICG900	Model	WL-IDG400	WL-IDG450	WL-IDG500	WL-IDG650	WL-IDG700	WL-IDG800	WL-IDG900
ΦD(mm)	450	500	635	700	800	900	ΦD(mm)	400	450	500	635	700	800	900
H(mm)	660	745	805	885	1000	1115	H(mm)	750	815	870	875	980	1145	1270
A(mm)	260	280	310	360	385	430	A(mm)	500	565	610	625	725	845	970
B(mm)	75	75	95	95	150	150	B(mm)	73	75	75	95	95	150	150
C(mm)	125	125	125	125	220	220	M(mm)	609	674	719	734	835	988	1113
M(mm)	444	464	494	534	680	725	N(mm)	550	615	660	676	776	908	1032
ΦP(mm)	390	390	565	565	790	790	ΦP(mm)	390	390	390	565	565	790	790
T(mm)	250	280	300	350	420	480	T(mm)	160	220	260	300	400	500	550

Model	Pipe Size		Filter Area (m ²)	Design Flow		Sand Weight (kg)	Filter Diameter (mm)	Filter Height (mm)
	inches	mm		m ³ /h	lpm			
WL-ICG450	1.5	50	0.16	8.0	133	45	450	660
WL-ICG500	1.5	50	0.20	10.0	166	80	500	745
WL-ICG650	1.5	50	0.32	15.0	250	130	635	805
WL-ICG700	1.5	50	0.38	19.0	317	190	700	885
WL-ICG750	2.0	63	0.44	22.0	367	230	750	1000
WL-ICG800	2.0	63	0.50	25.0	417	260	800	1000
WL-ICG900	2.0	63	0.64	32.0	533	400	900	1115

Model	Pipe Size		Filter Area (m ²)	Design Flow		Sand Weight (kg)	Filter Diameter (mm)	Filter Height (mm)
	inches	mm		m ³ /h	lpm			
WL-IDG400	1.5	50	0.13	6.0	100	30	400	750
WL-IDG450	1.5	50	0.16	8.0	133	45	450	815
WL-IDG500	1.5	50	0.20	10.0	166	80	500	860
WL-IDG650	1.5	50	0.32	15.0	250	130	635	875
WL-IDG700	1.5	50	0.38	19.0	317	190	700	1000
WL-IDG800	2.0	63	0.50	25.0	417	300	800	1145
WL-IDG900	2.0	63	0.64	32.0	533	450	900	1270

STANDARD: MAXIMUM WORKING PRESSURE: 36psi/2.5kg/cm² MAXIMUM OPERATING WATER TEMPERATURE≤50°C MAXIMUM TESTING PRESSURE:58psi/4.0kg/cm²
 OPTIONAL: MAXIMUM WORKING PRESSURE: 58psi/4.0kg/cm² MAXIMUM OPERATING WATER TEMPERATURE≤50°C MAXIMUM TESTING PRESSURE:86psi/6.0kg/cm²

CARTRIDGE FILTER

Features:

- Compact and light weight.
- UV resistant tank.
- Heavy duty ring-lock lid allows easy cleaning and replacement of the cartridge element.
- Screw type air bleeder for easy removal of trapped air inside the filter tank.
- High quality oil filled pressure gauge for easy inspection of the operation pressure.
- Application to swimming pool & spa.

- ◆ Maximum Working Pressure:250kpa/36psi/2.5bar
- ◆ Maximum Temperature:40°C (104F)



Cartridge Element

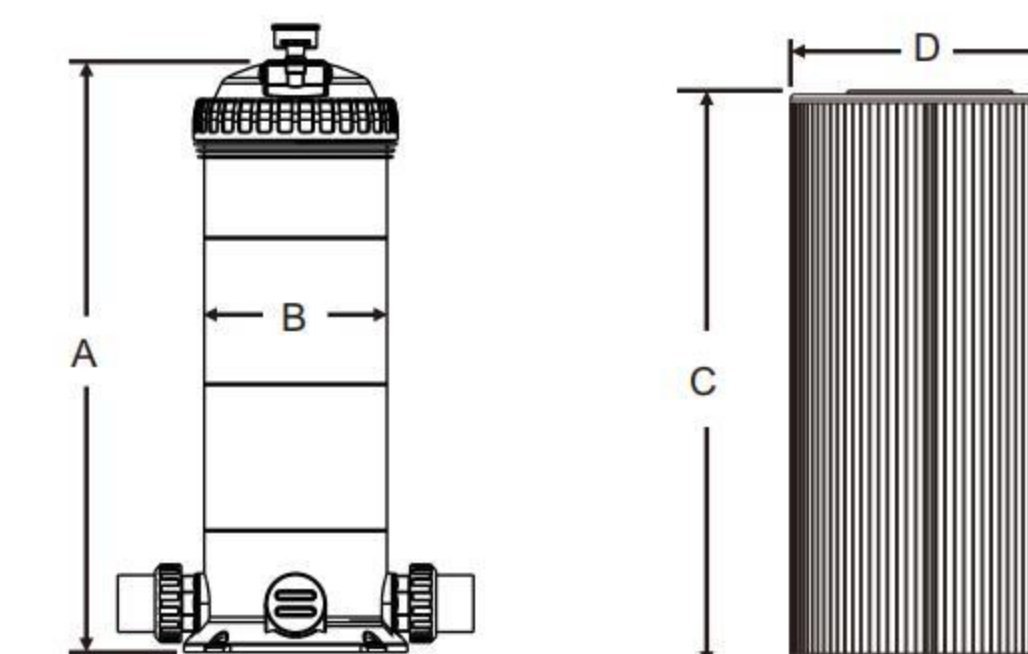

Model	WL-ZXG25	WL-ZXG50	WL-ZXG75	WL-ZXG100	WL-ZXG150	WL-ZXG200
A(mm)	368.3	548.3	728.3	908.3	1088.3	1268.3
B(mm)	225	225	225	225	225	225

Model	WL-ZXG25	WL-ZXG50	WL-ZXG75	WL-ZXG100	WL-ZXG150	WL-ZXG200
C(mm)	184.5	364.5	544.5	724.5	904.5	1091.0
D(mm)	183	183	183	183	183	183

Model	Pipe Size		Filter Area (m ²)	Design Flow		Micron (μm)	Tank Diameter (mm)	Tank Height (mm)
	inches	mm		m ³ /h	lpm			
WL-ZXG25	1.5	50	2.25	5.50	92	≤20	225	368.3
WL-ZXG50	1.5	50	4.63	11.40	190	≤20	225	548.3
WL-ZXG75	1.5	50	7.00	17.00	283	≤20	225	728.3
WL-ZXG100	1.5	50	9.40	22.90	382	≤20	225	908.3
WL-ZXG150	2.0	63	13.72	33.40	556	≤20	225	1088.3
WL-ZXG200	2.0	63	16.82	40.90	681	≤20	225	1268.3

MAXIMUM WORKING PRESSURE:36psi/2.5bar/cm², MAXIMUM TEMPERATURE ≤40°C

"P-DYG" SERIES FILTER SYSTEM

Features:

- Easy to install.
- LAWIM filtration system is equipped with the most optimal combination of our filter and pump.
- Injection-molded mounting base makes filtration system work more stable.
- Unitized thermal plastic filter tank, tough, durable and suitable for many different weather condition.
- Circulation pump with good performance, corrosion-proof and quiet.

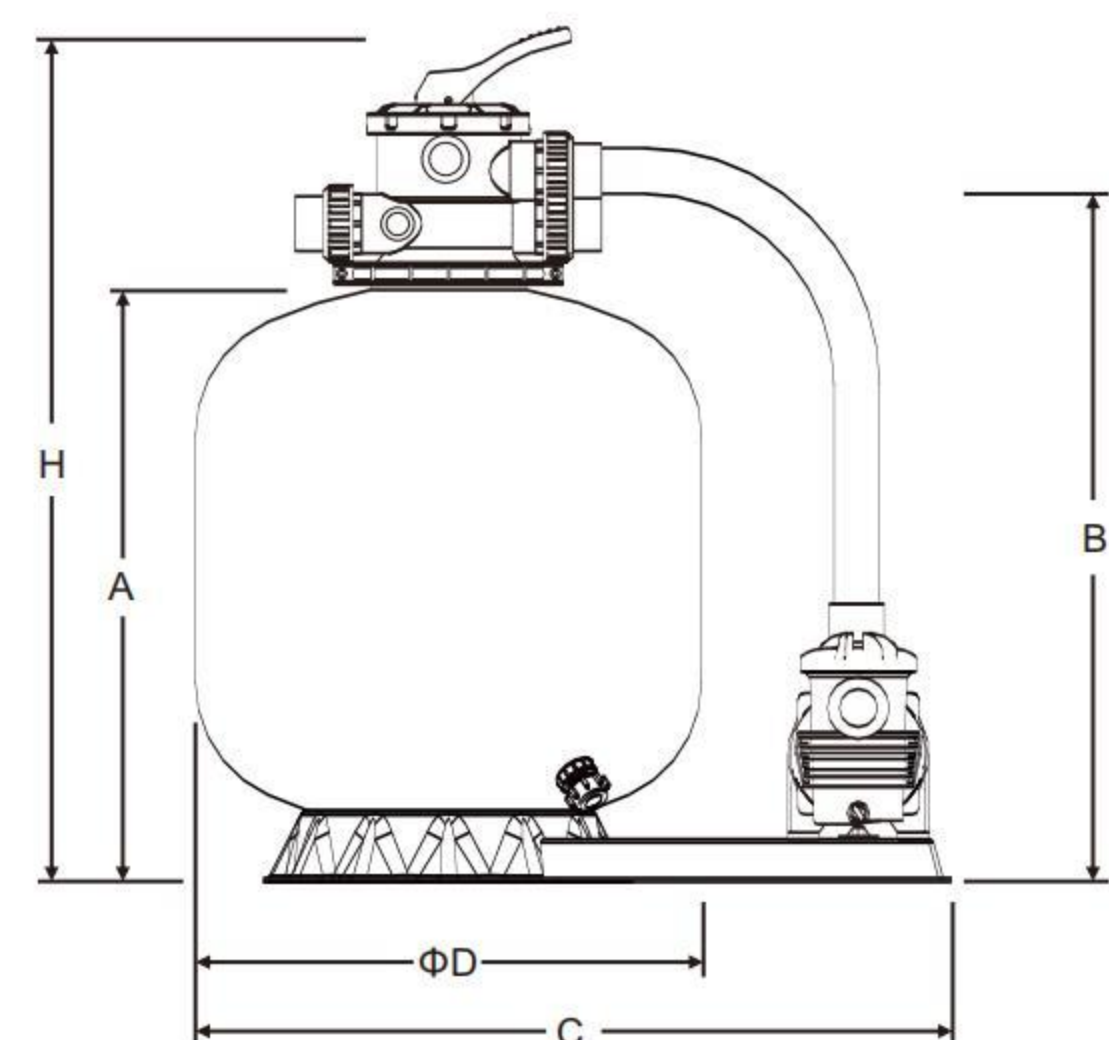

ΦD(mm)	350	410	450	535	635
H(mm)	750	770	830	870	970
A(mm)	495	515	575	615	715
B(mm)	545	565	625	665	765
C(mm)	570	570	770	770	770

QH.Curve of The Pump

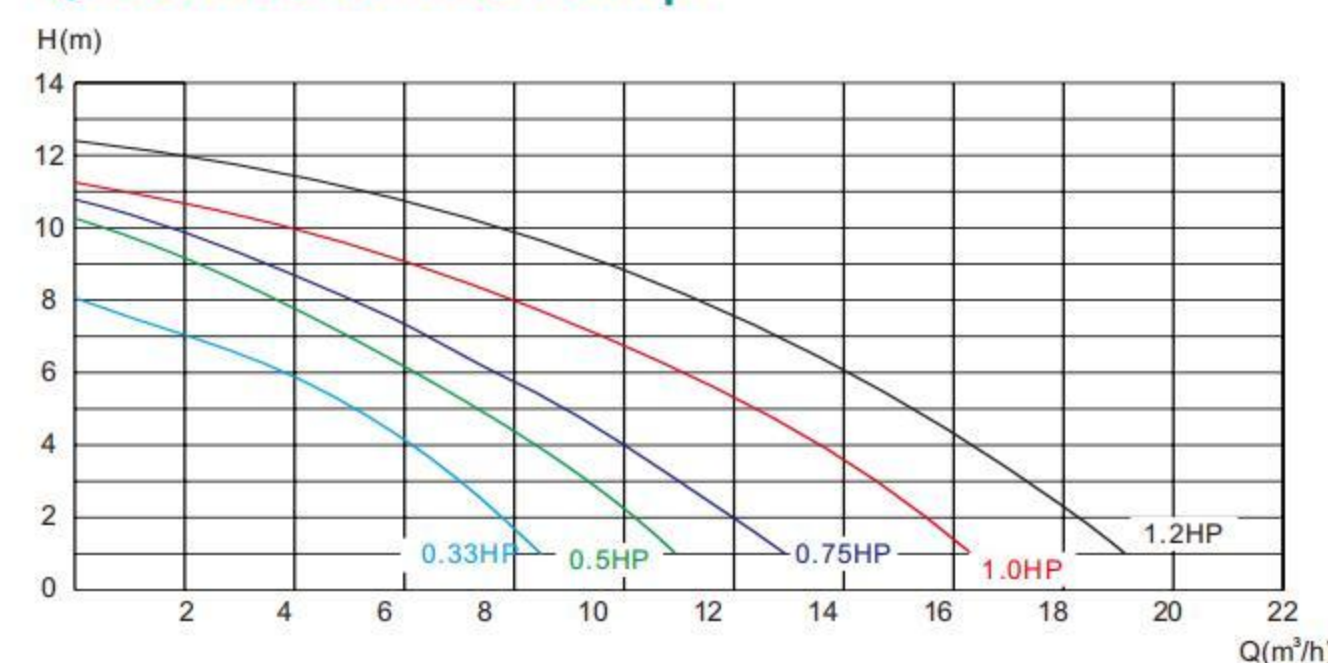

Model	Pipe Size		Filter Area (m ²)	Design Flow		0.5-0.8mm Sand Weight (kg)	Tank Volume (m ³)	Tank Weight (kg)	Valve Weight (kg)	Matching Pump (HP)
	inches	mm		m ³ /h	lpm					
P-DYG350	1.5	50	0.10	4.50	75	25	0.06	4.0	3	KP256/0.33HP
P-DYG400	1.5	50	0.13	6.50	108	34	0.09	5.0	3	KP256/0.33HP
P-DYG450	1.5	50	0.16	8.00	133	50	0.15	6.5	3	KP356/0.5HP
P-DYG500	1.5	50	0.23	11.50	192	80	0.20	9.2	3	KP756/1.0HP
P-DYG650	1.5	50	0.32	16.00	267	160	0.32	12.1	3	KP856/1.2HP

MAXIMUM WORKING PRESSURE: 36psi/2.5kg/cm²(PLASTIC CLAMP)

MAXIMUM OPERATING WATER TEMPERATURE≤43°C

"P-DYG" SERIES FILTER SYSTEM

The integrated circulation, filtration and sterilization unit is assembled with LASWIM plastic sand filter, circulation pump and chemical feeder. The unit is a multifunctional system assembled with precision, simple to operate, easy to install. It's the optimal choice for filtering movable and inflated pools.

Features:

- Compact design for easy carriage and quick to install. Contains all the functions of circulation, filtration and sterilization, ready to use.
- The base uses singular forming which makes the base strong and durable. The operation of the unit is stable and reliable.
- The circulation pump has superior performance and extremely quiet during operation.
- The filter uses UV proof food-level PE material to produce that is safe, eco-friendly and anti-corrosive.
- The pill dispenser uses hard tube connection, it is easy to use.
- The whole unit is accurately assembled, it is easy to install and maintain, it is suitable for moving pools and private pools.

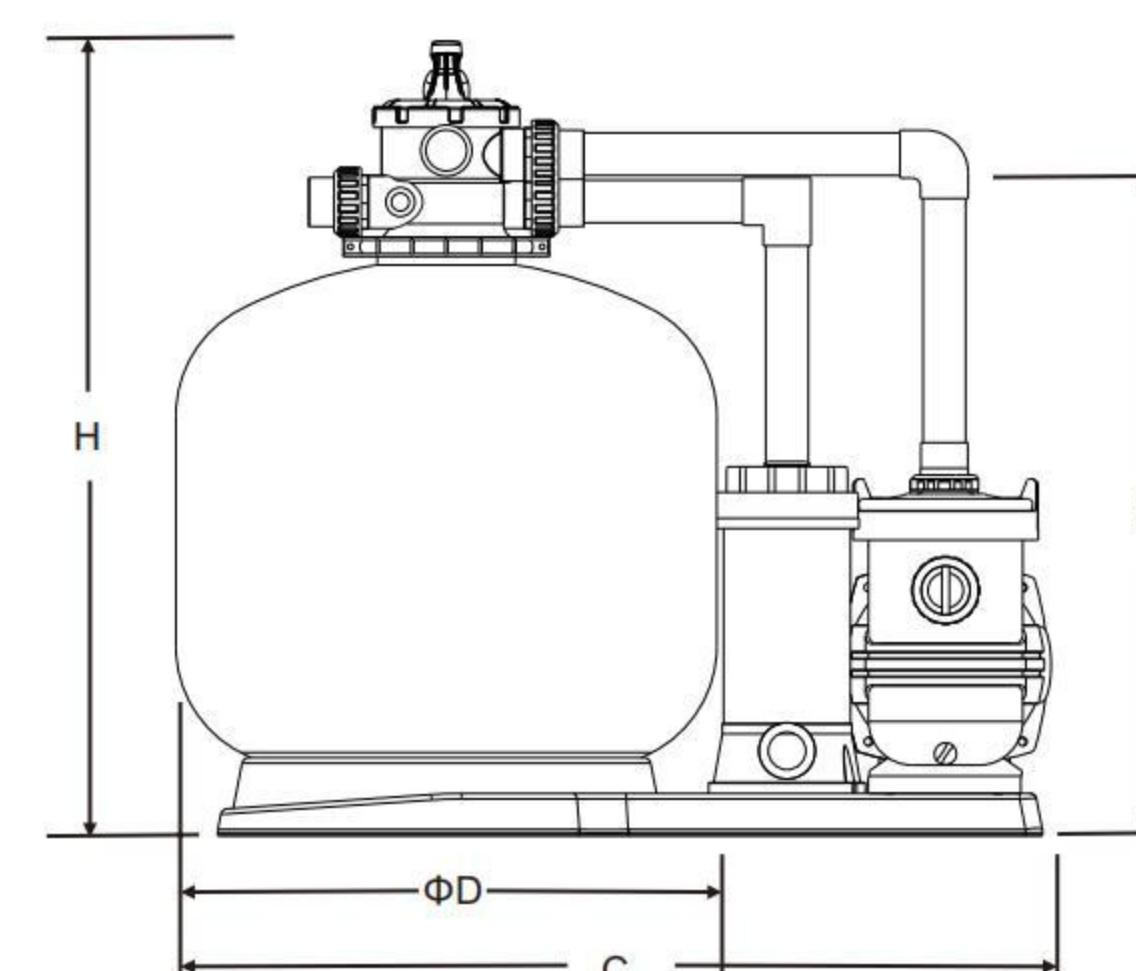

ΦD(mm)	635
H(mm)	970
A(mm)	715
B(mm)	765
C(mm)	1020

QH.Curve of The Pump

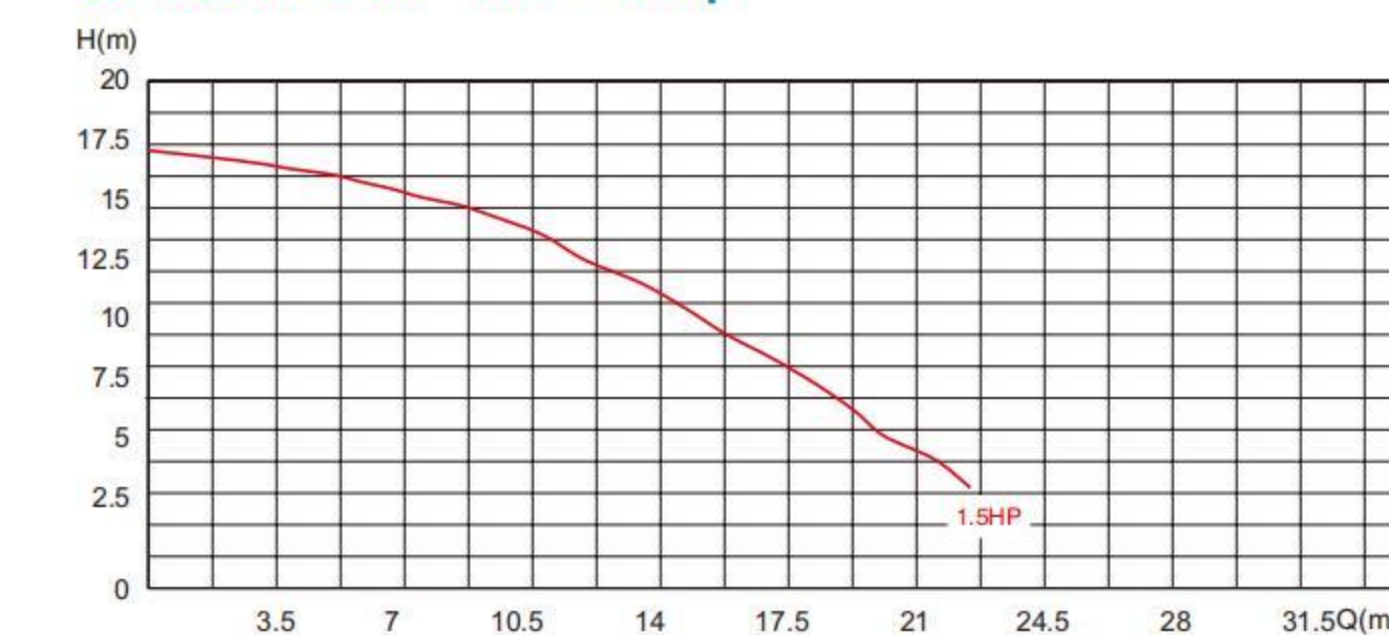

Model	Pipe Size		Filter Area (m ²)	Design Flow		0.5-0.8mm Sand Weight (kg)	Tank Volume (m ³)	Tank Weight (kg)	Valve Weight (kg)	Matching Pump (HP)	Chemical feeder
	inches	mm		m ³ /h	lpm						
WL-P-DYG650YH	1.5	50	0.32	16	267	160	0.32	13	3	HLLF150M	CL-200

MAXIMUM WORKING PRESSURE: 36psi/2.5kg/cm²(PLASTIC CLAMP)

MAXIMUM OPERATING WATER TEMPERATURE ≤43°C

"RDG" SERIES FILTER SYSTEM

RDG300 series filtration system is specially designed for domestic swimming pool. The component design is easy to assemble, and the installation is simple to operate; A variety of connection sizes can meet different usage scenarios. The RDG300K is equipped with strainer basket, while the RDG300X is not, so you will have more choices.



RDG300K



RDG300X



RDG300K SERIES SAND FILTER SYSTEM

Includes:

- 12" Durable top mount plastic filter tank
- Standard: 4-Way Multiport Valve (Optional: 6-Way Multiport Valve)
- 0.33HP Water Pump (With Strainer Basket)

RDG300X SERIES SAND FILTER SYSTEM

Includes:

- 12" Durable top mount plastic filter tank
- Standard: 4-Way Multiport Valve (Optional: 6-Way Multiport Valve)
- 0.25HP Water Pump (Without Strainer Basket)

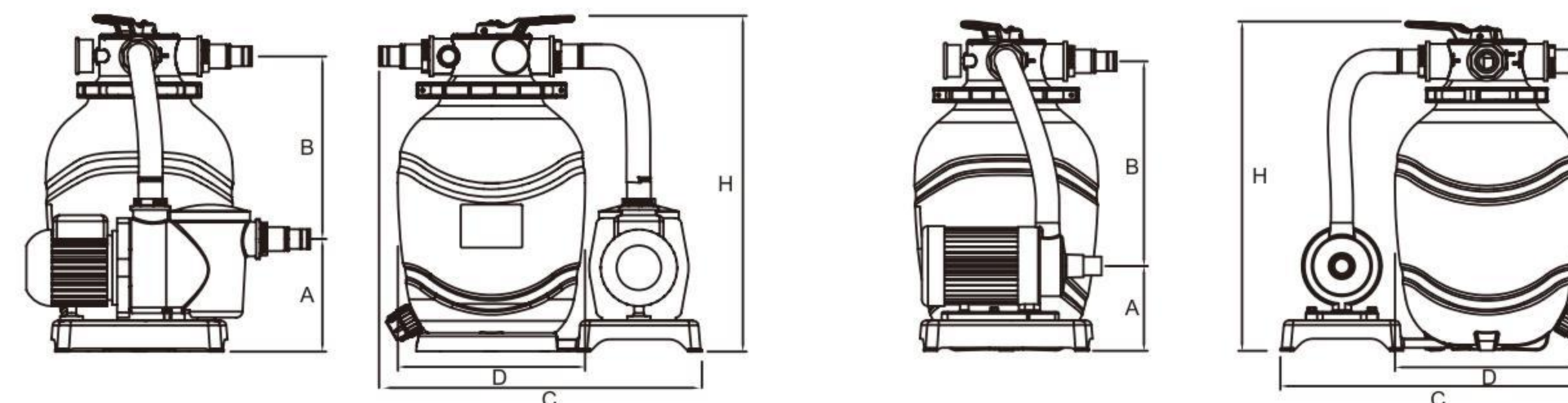

RDG300K

RDG300X

Product Dimensions

Model	RDG300K	RDG300X
A(mm)	183	140
B(mm)	297	340
C(mm)	525	525
D(mm)	305	305
H(mm)	546	546

QH.Curve of the pump

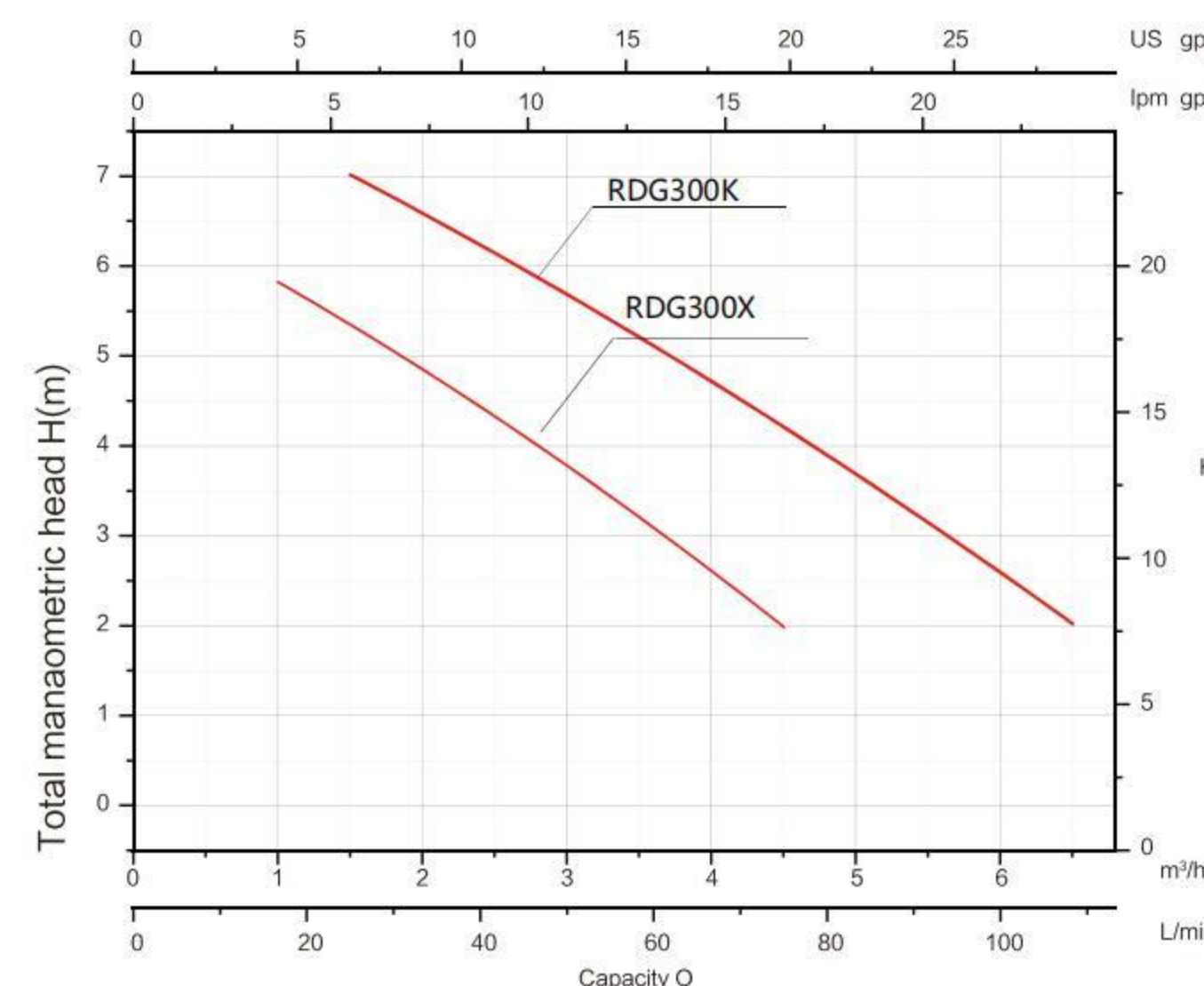

Optional:

6-way multiport valve



Model	Filter size	Pump Power (HP)	Filter Area (m²)	Flow rate		Pump flow rate		Sand weight 0.5-0.8mm (kg)	Multiport valve	Pipe connection
				m³/h	lpm	m³/h	lpm			
RDG300K-4W	12"	0.33	0.073	3.65	60.8	8.2	136.67	20	4-way	32/38mm; 1.5"/50mm (optional)
RDG300X-4W	12"	0.25	0.073	3.65	60.8	6.5	108.33	20	4-way	
RDG300K-6W	12"	0.33	0.073	3.65	60.8	8.2	136.67	20	6-way	
RDG300X-6W	12"	0.25	0.073	3.65	60.8	6.5	108.33	20	6-way	

"GB" SERIES FILTER SYSTEM

POOL FILTERS

Features:

- Easy to install.
- LASWIM filtration system is equipped with the most optimal combination of our filter and pump.
- Injection-molded mounting base makes filtration system work more stable.
- Unitized thermal plastic inner tank with fiberglass twining around outside, much more strong, durable and suitable for many different weather condition.
- Circulation pump with good performance, corrosion-proof and quiet.

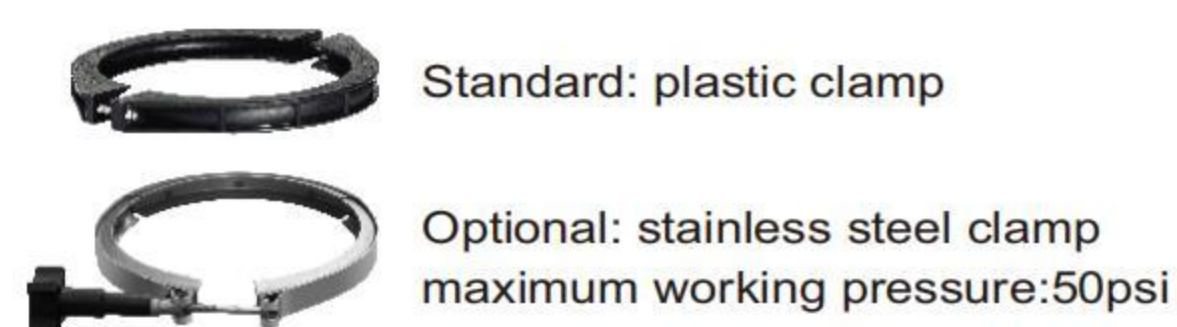
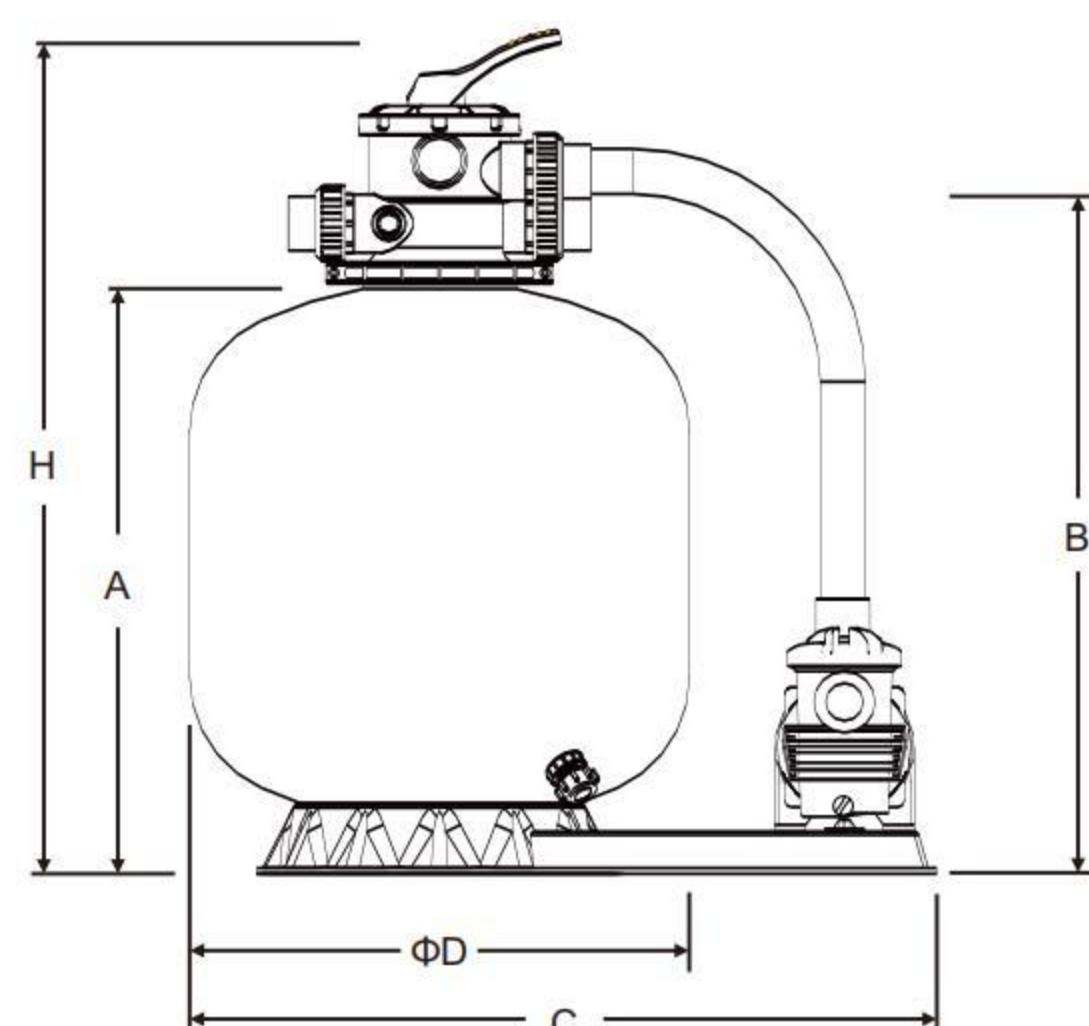

QH.Curve of The Pump

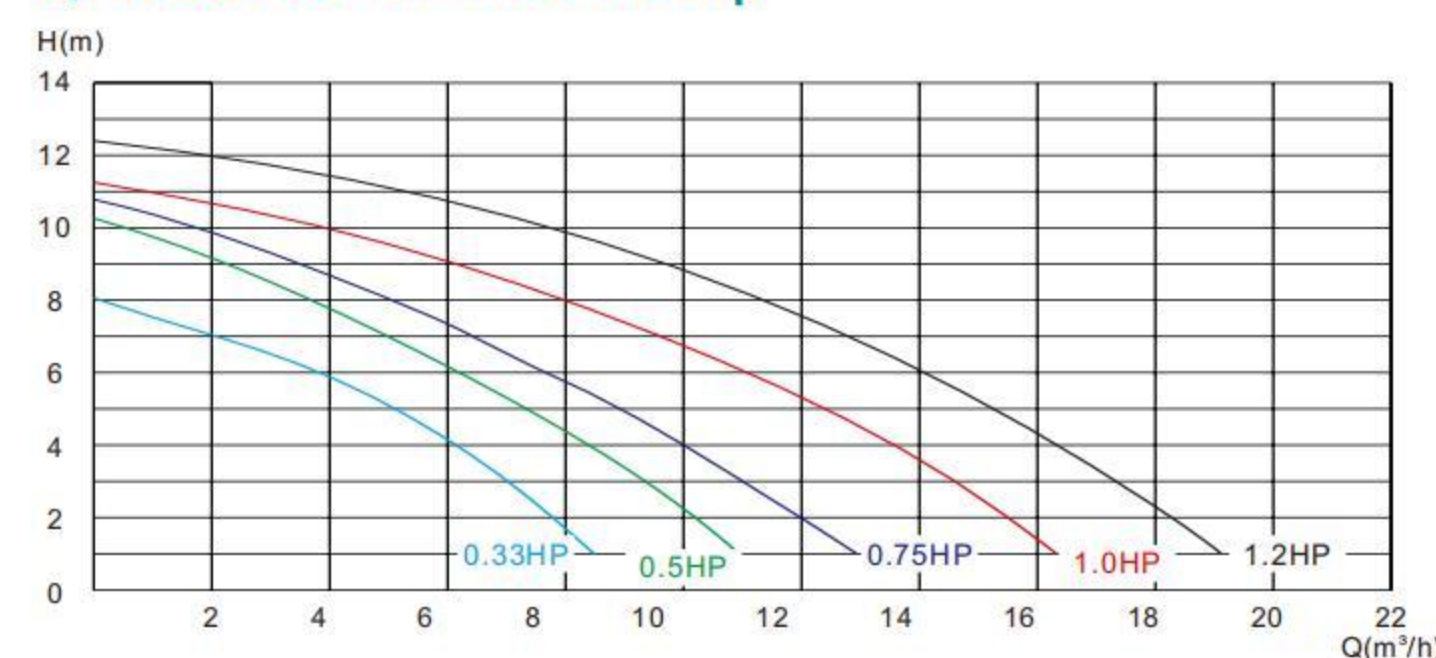

ΦD(mm)	350	410	450	535	635
H(mm)	750	770	830	870	970
A(mm)	495	515	575	615	715
B(mm)	545	565	625	665	765
C(mm)	570	570	770	770	770

Model	Pipe Size		Filter Area (m ²)	Design Flow		0.5-0.8mm Sand Weight (kg)	Tank Volume (m ³)	Tank Weight (kg)	Valve Weight (kg)	Matching Pump (HP)
	inches	mm		m ³ /h	lpm					
WL-GB350	1.5	50	0.10	4.50	75	25	0.06	4.5	3	KP256/0.33HP
WL-GB400	1.5	50	0.13	6.50	108	34	0.09	5.5	3	KP256/0.33HP
WL-GB450	1.5	50	0.16	8.00	133	50	0.15	7.0	3	KP356/0.5HP
WL-GB500	1.5	50	0.23	11.50	192	80	0.20	9.8	3	KP756/1.0HP
WL-GB650	1.5	50	0.32	16.00	267	160	0.32	13.0	3	KP856/1.2HP

STANDARD: MAXIMUM WORKING PRESSURE: 36psi/2.5kg/cm² MAXIMUM OPERATING WATER TEMPERATURE: ≤50°C MAXIMUM TESTING PRESSURE: 58psi/4.0kg/cm²

DEEP BED SAND FILTERS

POOL FILTERS

High quality and high performance are aesthetically designed for water treatment.

High density fiberglass sand filters are constructed by the latest engineering technology. The improvement of flow ability provides an ultra-pure water filtration. The fiberglass winding design allows the filter to have extra strength and resistance to chemical and corrosives. They're the most recommendable equipment for the application of water treatment.



WL-DDG13400-WL-DDG15700 WL-BDG10400-WL-BDG13700

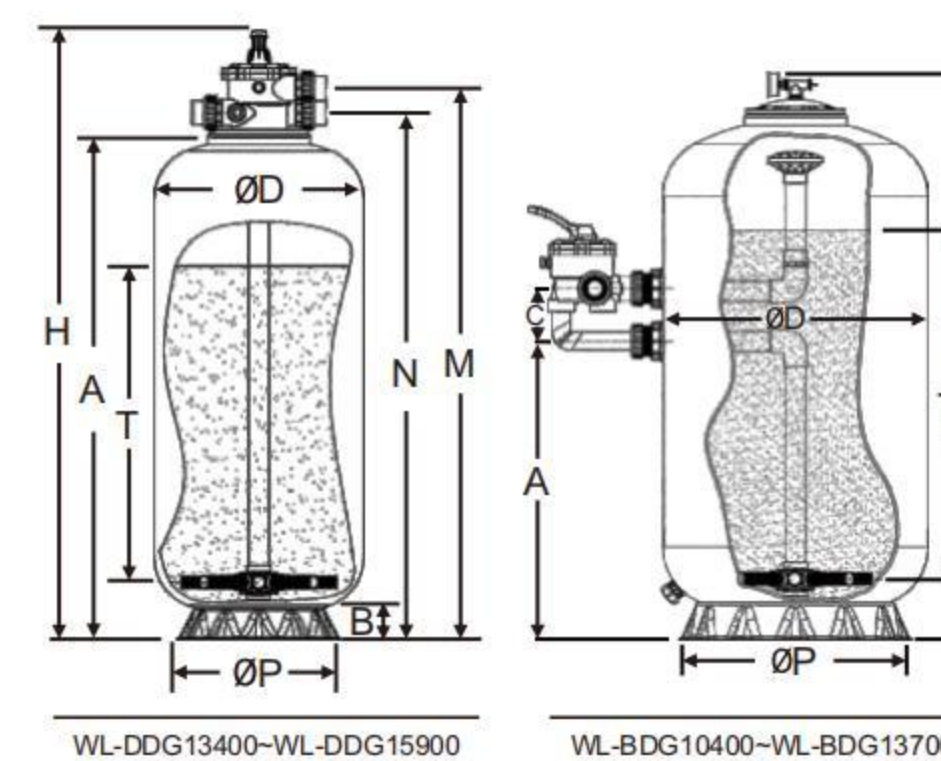

WL-DDG13400-WL-DDG15700

ΦD (mm)	400	450	530	630	700	400	450	530	630	700
H (mm)	1300	1300	1300	1300	1300	1500	1500	1500	1500	1500
A (mm)	1062	1062	1062	1062	1062	1262	1262	1262	1262	1262
B (mm)	75	75	75	95	95	75	75	75	95	95
M (mm)	1174	1174	1174	1174	1174	1374	1374	1374	1374	1374
N (mm)	1115	1115	1115	1115	1115	1315	1315	1315	1315	1315
ΦP (mm)	390	390	390	565	565	390	390	390	565	565
T (mm)	650	650	650	630	630	850	850	850	830	830

WL-BDG10400-WL-BDG13700

ΦD (mm)	400	450	530	630	700	400	450	530	630	700
H (mm)	1160	1160	1160	1160	1160	1360	1360	1360	1360	1360
A (mm)	660	660	660	660	660	860	860	860	860	860
C (mm)	125	125	125	125	125	125	125	125	125	125
ΦP (mm)	390	390	390	565	565	390	390	390	565	565
T (mm)	650	650	650	650	650	850	850	850	850	850

Model	Pipe Size		Filter Area (m ²)	Design Flow		0.4-0.8mm Sand Weight (kg)	Tank Diameter (mm)	Tank Height (mm)
	inches	mm		m ³ /h	lpm			
WL-DDG13400	1.5	50	0.13	4.5	75	120	400	1300
WL-DDG13450	1.5	50	0.16	5.6	93	150	450	1300
WL-DDG13500	1.5	50	0.20	7.0	117	185	530	1300
WL-DDG13600	1.5	50	0.32	11.2	187	245	630	1300
WL-DDG13700	1.5	50	0.37	13.0	217	345	700	1300
WL-DDG15400	1.5	50	0.13	3.9	65	150	400	1500
WL-DDG15450	1.5	50	0.16	4.8	80	195	450	1500
WL-DDG15500	1.5	50	0.20	6.0	100	240	530	1500
WL-DDG15600	1.5	50	0.32	9.6	160	325	630	1500
WL-DDG15700	1.5	50	0.37	11.0	183	400	700	1500
WL-DDG15800	2.0	63	0.50	15.0	250	500	800	1500
WL-DDG15900	2.0	63	0.64	19.2	320	590	900	1500

Model	Pipe Size		Filter Area (m ²)	Design Flow		0.4-0.8mm Sand Weight (kg)	Tank Diameter (mm)	Tank Height (mm)
	inches	mm		m ³ /h	lpm			
WL-BDG10400	1.5	50	0.13	4.5	75	110	400	1160
WL-BDG10450	1.5	50	0.16	5.6	93	140	450	1160
WL-BDG10500	1.5	50	0.20	7.0	117	170	500	1160
WL-BDG10600	1.5	50	0.32	11.2	187	230	630	1160
WL-BDG10700	1.5	50	0.37	13.0	217	325	700	1160
WL-BDG13400	1.5	50	0.13	3.9	65	140	400	1360
WL-BDG13450	1.5	50	0.16	4.8	80	185	450	1360
WL-BDG13500	1.5	50	0.20	6.0	100	225	500	1360
WL-BDG13600	1.5	50	0.32	9.6	160	310	630	1360
WL-BDG13700	1.5	50	0.37	11.0	183	430	700	1360

MAXIMUM WORKING PRESSURE: 58psi/4.0bar/cm², MAXIMUM TEMPERATURE ≤50°C, MAXIMUM TESTING PRESSURE: 86psi/6.0bar/cm²

COMMERCIAL DEEP BED SAND FILTER

POOL FILTERS

It is made of high quality fiberglass which is chemical and sunlight resistance, and can be installed out-of-doors. Side Mount, easily for operating. It also can be feeded and mixed different filtrate medium (Such as: Zeolite, Sand and Active carbon) to make the water more clear. It is best choice for residential area and public water.

This filter can be with flange or valve
With Manhole, Sight glass, Collector arm.
Optional : Nozzle plate



Collector Arms

Nozzle Plate



With Flange

With Valve

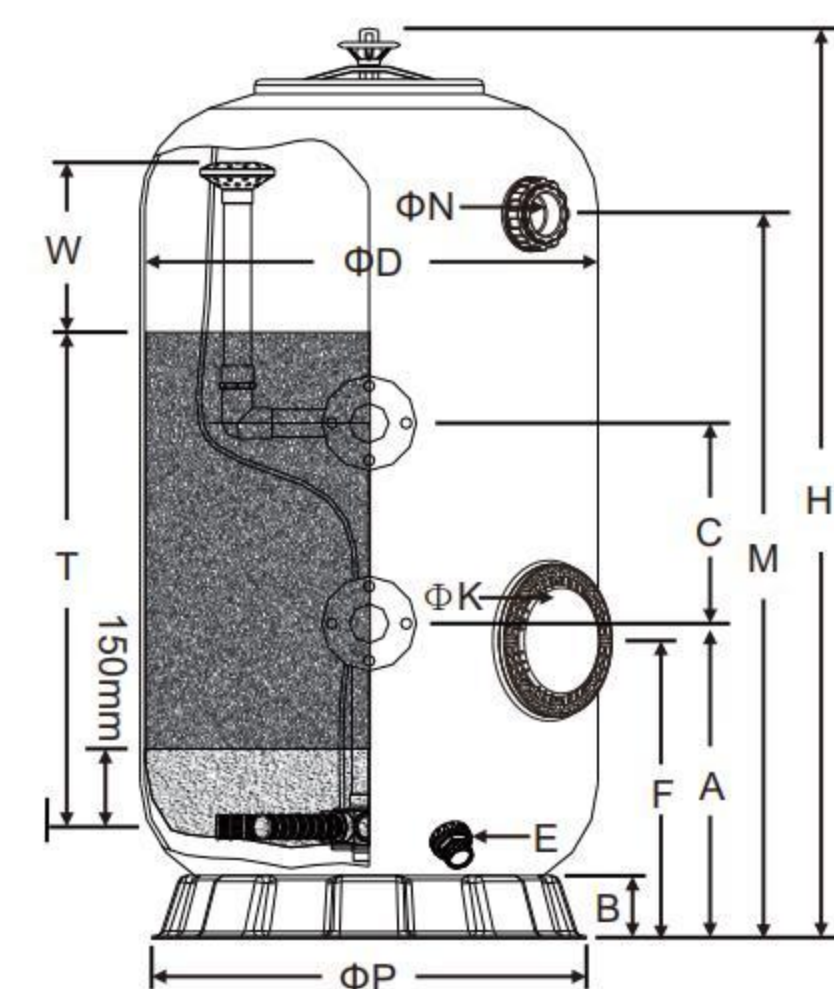

With Lateral

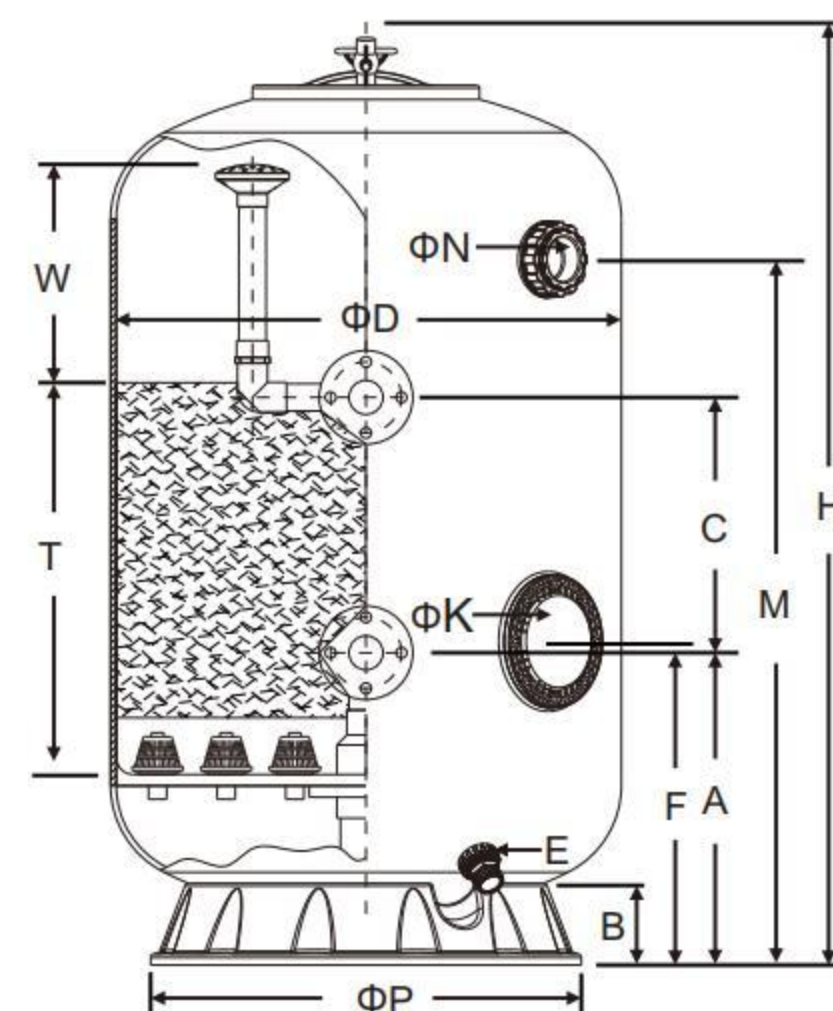

With Nozzle Plate

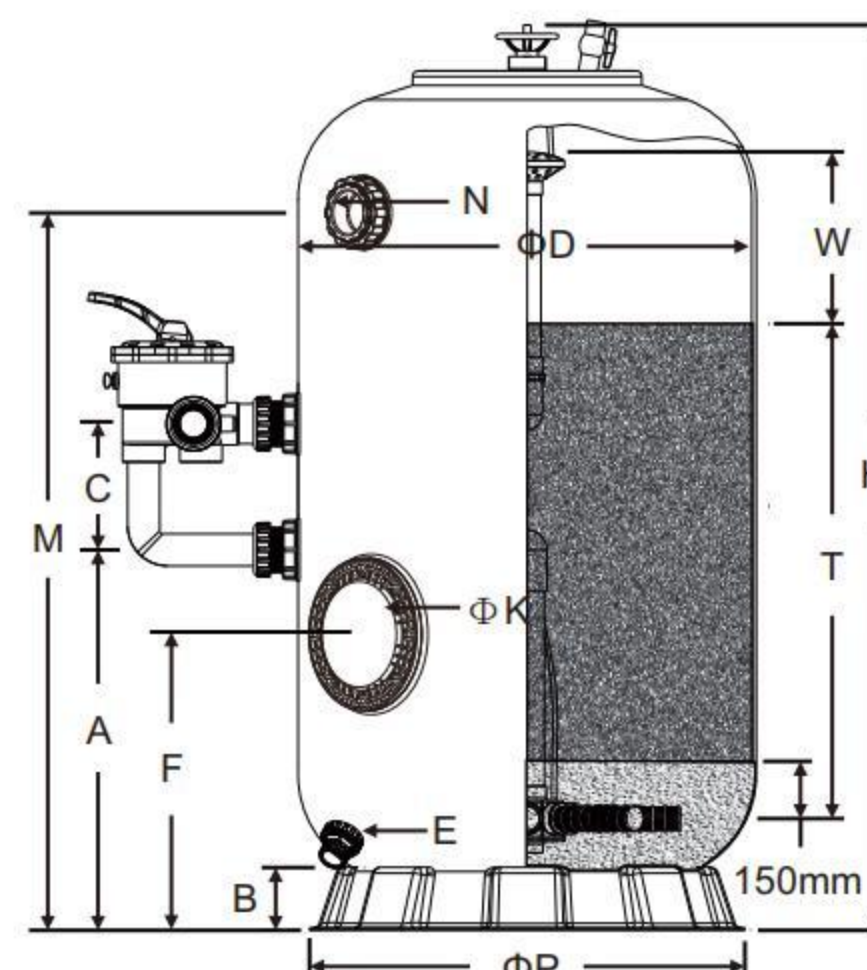

With Valve

Model	15800	15900	151000	151200	20800	20900	201000	201200
D (mm)	800	900	1000	1200	800	900	1000	1200
H (mm)	1600	1600	1600	1600	2100	2100	2100	2100
A (mm)	550	550	550	650	800	800	800	800
B (mm)	150	150	150	180	150	150	150	180
C (mm)	350	350	350	350	350	350	350	350
E (mm)	40	40	40	40	40	40	40	40
F (mm)	520	520	520	600	520	520	520	600
K (mm)	180	180	180	180	180	180	180	180
M (mm)	1120	1120	1120	1120	1600	1600	1600	1600
N (mm)	80	80	80	80	80	80	80	80
P (mm)	790	790	790	1010	790	790	790	1010
T (mm)	800	800	800	800	1250	1250	1250	1250
W (mm)	350	350	350	350	400	400	400	400

Model	15800	15900	151000	151200	20800	20900	201000	201200
D (mm)	800	900	1000	1200	800	900	1000	1200
H (mm)	1600	1600	1600	1600	2100	2100	2100	2100
A (mm)	550	550	550	650	800	800	800	800
B (mm)	150	150	150	180	150	150	150	180
C (mm)	350	350	350	350	350	350	350	350
E (mm)	40	40	40	40	40	40	40	40
F (mm)	600	600	600	680	600	600	600	680
M (mm)	1120	1120	1120	1120	1600	1600	1600	1600
K (mm)	180	180	180	180	180	180	180	180
N (mm)	80	80	80	80	80	80	80	80
P (mm)	790	790	790	790	790	790	790	1010
T (mm)	800	800	800	800	1250	1250	1250	1250
W (mm)	160	160	160	160	160	160	160	160

Model	15800	15900	151000	151200	20800	20900	201000	201200
D (mm)	800	900	1000	1200	800	900	1000	1200
H (mm)	1600	1600	1600	1600	2100	2100	2100	2100
A (mm)	550	550	550	650	800	800	800	800
B (mm)	120	120	145	165	120	120	145	165
C (mm)	220	220	220	220	220	220	220	220
E (mm)	40	40	40	40	40	40	40	40
F (mm)	520	520	520	600	520	520	520	600
K (mm)	180	180	180	180	180	180	180	180
M (mm)	1120	1120	1120	1120	1600	1600	1600	1600
N (mm)	80	80	80	80	80	80	80	80
P (mm)	790	790	790	980	790	790	790	1010
T (mm)	800	800	800	800	1250	1250	1250	1250
W (mm)	350	350	350	350	400	400	400	400

Model	Connections		Filter Area (m ²)	Design Flow		Sand Weight 0.5-0.8mm(kg)	Gravel Weight 1-2mm(kg)	Tank Diameter (mm)	Tank Height (mm)
	inches	mm		m ³ /h	lpm				
WL-ECG15800V	2	63	0.50	20.0	333	455	170	800	1600
WL-ECG15900V	2	63	0.64	25.6	426	585	230	900	1600
WL-ECG151000V	2	63	0.79	31.6	526	720	270	1000	1600
WL-ECG151200V	2	63	1.13	40.0	666	1030	450	1200	1600
WL-ECG151200V-2.5	2.5	75	1.13	45.2	753	1030	450	1200	1600
WL-ECG20800V	2	63	0.50	15.0	250	770	170	800	2100
WL-ECG20900V	2	63	0.64	19.0	317	990	230	900	2100
WL-ECG201000V	2	63	0.79	23.7	395	1220	270	1000	2100
WL-ECG201200V	2	63	1.13	30.0	500	1740	450	1200	2100
WL-ECG201200V-2.5	2.5	75	1.13	33.9	565	1740	450	1200	2100

With Flange

Model	Connections		Filter Area (m ²)	Design Flow		Sand Weight 0.5-0.8mm(kg)	Gravel Weight 1-2mm(kg)	Tank Diameter (mm)	Tank Height (mm)
	inches	mm		m ³ /h	lpm				
WL-ECG15800F	2	63	0.50	20.0	333	455	170	800	1600
WL-ECG15900F	2	63	0.64	25.6	426	585	230	900	1600
WL-ECG151000F	2	63	0.79	31.6	526	720	270	1000	1600
WL-ECG151200F	3	90	1.13	45.2	753	1030	450	1200	1600
WL-ECG151400F	3	90	1.54	61.6	1026	1030	450	1400	1600
WL-ECG20800F	2	63	0.50	15.0	250	770	170	800	2100
WL-ECG20900F	2	63	0.64	19.0	317	990	230	900	2100
WL-ECG201000F	2	63	0.79	23.7	395	1220	270	1000	2100
WL-ECG201200F	3	90	1.13	33.9	565	1740	450	1200	2100
WL-ECG201400F	3	90	1.54	46.2	770	2100	500	1400	2100

With Nozzle

Model	Connections		Filter Area (m ²)	Design Flow		Sand Weight 0.5-0.8mm(kg)	Gravel Weight 1-2mm(kg)	Tank Diameter (mm)	Tank Height (mm)
	inches	mm		m ³ /h	lpm				
WL-ECG15800	2	63	0.50	20.0	333	455	110	800	1600
WL-ECG15900	2	63	0.64	25.6	426	585	145	900	1600
WL-ECG151000	2	63	0.79	31.6	526	720	175	1000	1600
WL-ECG151200	3	90	1.13	45.2	753	1030	255	1200	1600
WL-ECG151400	3	90	1.54	61.6	1026	1100	320	1400	1600
WL-ECG20800	2	63	0.50	15.0	250	770	110	800	2100
WL-ECG20900	2	63	0.64	19.0	317	990	145	900	2100
WL-ECG201000	2	63	0.79	23.7	395	1220	175	1000	2100
WL-ECG201200	3	90	1.13	33.9	565	1740	255	1200	2100
WL-ECG201400	3	90	1.54	46.2	770	2100	320	1400	2100

STANDARD: MAXIMUM WORKING PRESSURE: 36psi/2.5kg/cm² MAXIMUM OPERATING WATER TEMPERATURE≤50°C MAXIMUM TESTING PRESSURE:58psi/4.0kg/cm²
OPTIONAL: MAXIMUM WORKING PRESSURE: 58psi/4.0kg/cm² MAXIMUM OPERATING WATER TEMPERATURE≤50°C MAXIMUM TESTING PRESSURE:86psi/6.0kg/cm²

POOL FILTERS

COMMERCIAL HI-RATE SAND FILTERS

POOL FILTERS

Superior engineering and a company-wide commitment to customer satisfaction have produced a series of vertical filters that are built to be tougher, longer lasting and better performing than any other competing vertical commercial hi-rate sand filter.

Constructed of polyester resin and non-corrosive fiberglass filament winding, all internal components and connections are injection molded PVC. UV-resistance surface allows working under sunshine.

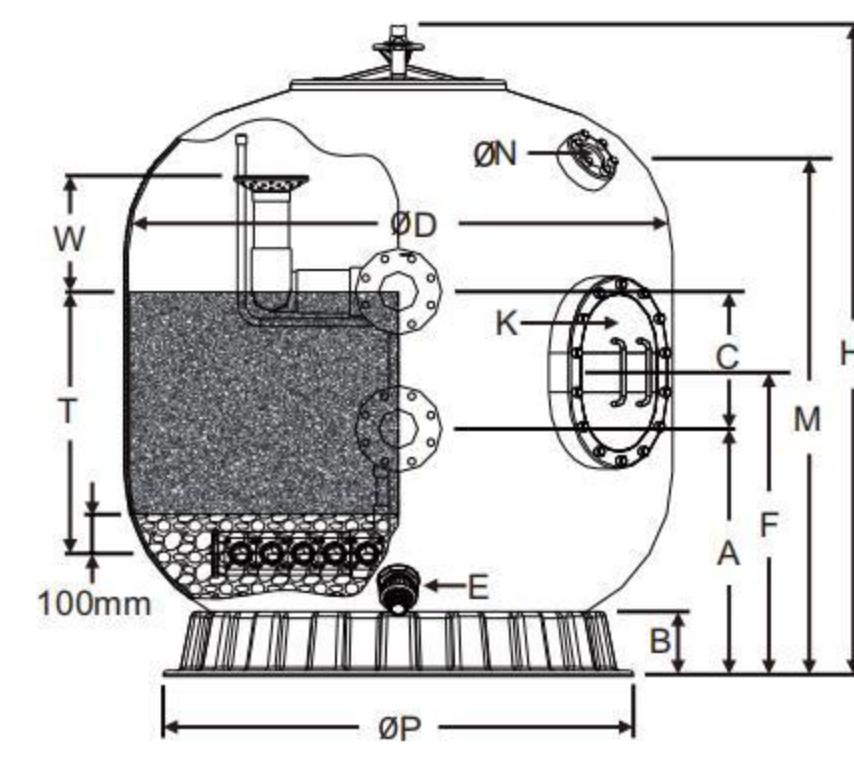

With Collector Arms

D (mm)	1200	1400	1600	1800	2000	2200	2300	2350	2500
H (mm)	1400	1600	1750	1950	2140	2350	2350	2350	2450
A (mm)	560	650	680	730	800	900	940	940	960
B (mm)	165	165	215	215	240	240	240	240	240
C (mm)	340	350	450	550	550	600	600	600	600
E (mm)	60	60	60	60	60	60	60	60	60
F (mm)	740	800	875	910	1050	1070	1070	1070	1100
K (mm)	180x180	400x300	400x300	400x300	400x300	400x300	400x300	400x300	400x300
M (mm)	1150	1250	1450	1650	1700	1750	1800	1800	1900
N (mm)	80	80	80	80	80	80	80	80	80
P (mm)	1010	1215	1450	1610	1800	1800	2010	2010	2010
T (mm)	600	700	800	850	900	1000	1000	1000	1050
W (mm)	300	300	320	320	350	400	400	400	400

Model	Flange Connections		Filter Area (m ²)	Design Flow		0.4-0.8mm Sand Weight (kg)	1-2mm Gravel Weight (kg)	Tank Diameter (mm)	Tank Height (mm)
	inches	mm		m ³ /h	lpm				
WL-CCG1200	3	90	1.13	45	750	750	300	1200	1420
WL-CCG1400	4	110	1.54	61	1016	1200	500	1400	1670
WL-CCG1600	4	110	2.01	80	1333	1850	750	1600	1750
WL-CCG1800	6	160	2.54	101	1683	2500	1050	1800	1950
WL-CCG2000	6	160	3.14	125	2083	3300	1150	2000	2140
WL-CCG2200	6	160	3.80	152	2532	4150	1470	2200	2350
WL-CCG2300	8	200	4.15	166	2766	4900	1600	2300	2350
WL-CCG2500	8	200	4.90	196	3265	6000	2200	2500	2450
WL-CCG3000	8	200	7.07	282	4698	8600	3300	3000	2650

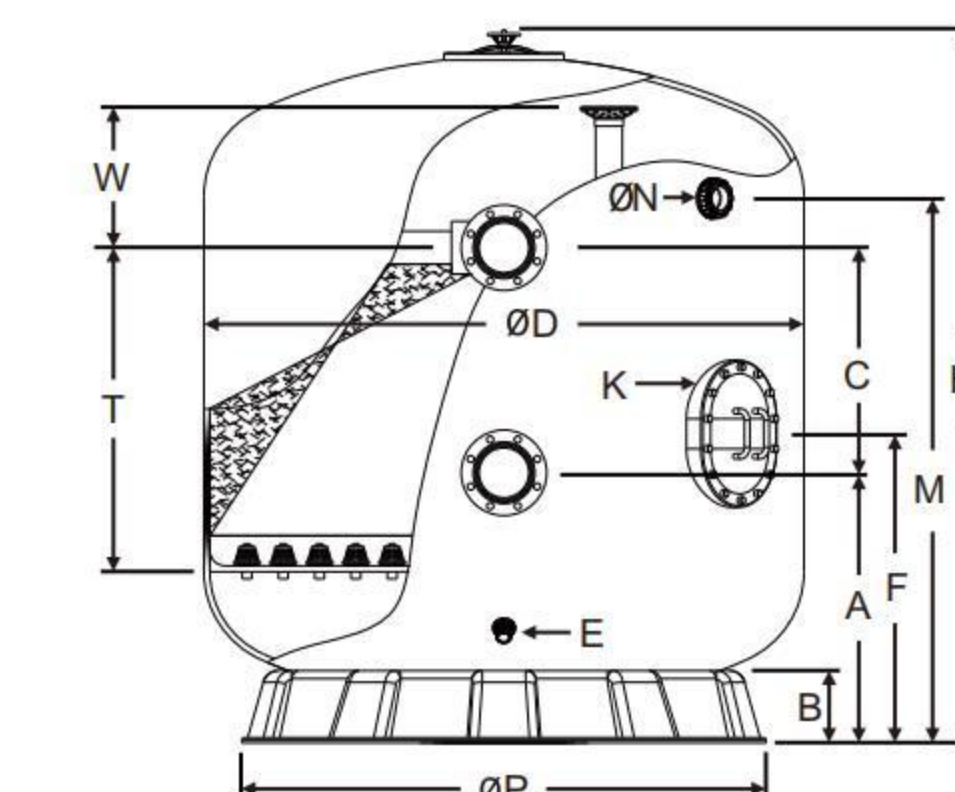

With Nozzle Plate

D (mm)	1420	1620	1830	2030	2300	2500
H (mm)	1900	2000	2100	2200	2350	2400
A (mm)	700	810	850	900	940	960
B (mm)	165	215	215	240	240	240
C (mm)	550	550	550	550	600	600
E (mm)	40	40	40	40	40	40
F (mm)	850	900	980	1030	1070	1100
K (mm)	400X300	400X300	400X300	400X300	400X300	400X300
M (mm)	1400	1500	1600	1700	1800	1900
N (mm)	80	80	80	80	80	80
P (mm)	1215	1450	1610	1800	2010	2010
T (mm)	1000	1000	1000	1000	1000	1050
W (mm)	300	320	320	350	400	400

Model	Flange Connections		Filter Area (m ²)	Design Flow		0.4-0.8mm Sand Weight (kg)	1-2mm Gravel Weight (kg)	Tank Diameter (mm)	Tank Height (mm)
	inches	mm		m ³ /h	lpm				
WL-CCG1400	4	110	1.54	61	1016	1800	220	1420	1900
WL-CCG1600	4	110	2.01	80	1333	2300	300	1620	2000
WL-CCG1800	6	160	2.54	101	1683	2900	360	1830	2100
WL-CCG2000	6	160	3.14	125	2083	3600	440	2030	2200
WL-CCG2300	8	200	4.15	166	2766	4800	580	2300	2350
WL-CCG2500	8	200	4.90	196	3265	5700	680	2500	2400
WL-CCG3000	8	200	7.07	282	4698	8250	980	3000	2650

STANDARD: MAXIMUM WORKING PRESSURE: 36psi/2.5kg/cm² MAXIMUM OPERATING WATER TEMPERATURE≤50°C MAXIMUM TESTING PRESSURE:58psi/4.0kg/cm²
 OPTIONAL: MAXIMUM WORKING PRESSURE: 58psi/4.0kg/cm² MAXIMUM OPERATING WATER TEMPERATURE≤50°C MAXIMUM TESTING PRESSURE:86psi/6.0kg/cm²

Optional: Sight glass, manhole, nozzle plate.



POOL FILTERS

HORIZONTAL SAND FILTERS

POOL FILTERS

Horizontal sand filters are made of polyester reinforced with fiberglass; they are totally anti-corrosive, and have high mechanical, chemical and thermal resistance, higher quality water is achieved with their greater filtering capacity. Indexes of turbidity and contaminants of the filtered water are reduced due to their increased retention capacity, The time between back washes increases proportionally with the height of the filter bed, meaning there are fewer interruptions in filtration, and lower water consumption, because the number of back washes needed is decreased and there is less erosion of the filtering material.

A horizontal filter is the ideal choice in cases where a great volume of water is to be treated, and in cases which require optimization of the available space, as a single horizontal filter can substitute up to 3 vertical filters of the same diameter simply by increasing its length.



Collector Arms

Top Diffuser

Cover Lid

Sand Drain

Pressure Control Manometer Panel



POOL FILTERS

Φ1200mm										
Model	L Length (mm)	Flange Connections		Filter Area (m ²)	Design Flow		0.4-0.8mm Sand Weight (kg)	1-2mm Gravel Weight (kg)	Tank Diameter (mm)	Tank Height (mm)
		inches	mm		m ³ /h	lpm				
WL-HF121900	1900	4	110	1.96	59	983	1100	430	1200	1390
WL-HF122300	2300	6	160	2.42	73	1216	1430	550	1200	1390
WL-HF122500	2500	6	160	2.65	79	1316	1750	700	1200	1390
WL-HF122700	2700	6	160	2.87	86	1433	2080	830	1200	1390
WL-HF123000	3000	6	160	3.21	96	1599	2330	925	1200	1390

Φ1400mm										
Model	L Length (mm)	Flange Connections		Filter Area (m ²)	Design Flow		0.4-0.8mm Sand Weight (kg)	1-2mm Gravel Weight (kg)	Tank Diameter (mm)	Tank Height (mm)
		inches	mm		m ³ /h	lpm				
WL-HF141900	1900	4	110	2.23	67	1116	2000	580	1400	1600
WL-HF142500	2500	6	160	3.02	91	1516	2750	800	1400	1600
WL-HF143000	3000	6	160	3.67	110	1833	3375	1000	1400	1600

Φ1600mm										
Model	L Length (mm)	Flange Connections		Filter Area (m ²)	Design Flow		0.4-0.8mm Sand Weight (kg)	1-2mm Gravel Weight (kg)	Tank Diameter (mm)	Tank Height (mm)
		inches	mm		m ³ /h	lpm				
WL-HF161900	1900	6	160	2.47	74	1233	2800	600	1600	1830
WL-HF162500	2500	6	160	3.36	101	1683	3800	850	1600	1830
WL-HF163000	3000	6	160	4.10	123	2049	4700	1050	1600	1830

Φ1800mm										
Model	L Length (mm)	Flange Connections		Filter Area (m ²)	Design Flow		0.4-0.8mm Sand Weight (kg)	1-2mm Gravel Weight (kg)	Tank Diameter (mm)	Tank Height (mm)
		inches	mm		m ³ /h	lpm				
WL-HF182500	2500	6	160	3.74	112	1866	4850	980	1800	2050
WL-HF183000	3000	6	160	4.58	137	2282	5930	1230	1800	2050
WL-HF183500	3500	8	200	5.41	162	2699	7000	1480	1800	2050
WL-HF184000	4000	8	200	6.25	187	3115	8080	1700	1800	2050

Φ2000mm										
Model	L Length (mm)	Flange Connections		Filter Area (m ²)	Design Flow		0.4-0.8mm Sand Weight (kg)	1-2mm Gravel Weight (kg)	Tank Diameter (mm)	Tank Height (mm)
		inches	mm		m ³ /h	lpm				
WL-HF202500	2500	6	160	4.34	130	2166	6000	1050	2000	2220
WL-HF203000	3000	6	160	5.30	159	2649	7450	1300	2000	2220
WL-HF203500	3500	8	200	6.25	187	3282	8900	1550	2000	2220
WL-HF204000	4000	8	200	7.21	216	3599	10350	1800	2000	2220
WL-HF204500	4500	8	200	8.16	245	4082	11800	2080	2000	2220

STANDARD: MAXIMUM WORKING PRESSURE: 36psi/2.5kg/cm² MAXIMUM OPERATING WATER TEMPERATURE: ≤50°C MAXIMUM TESTING PRESSURE: 58psi/4.0kg/cm²
 OPTIONAL: MAXIMUM WORKING PRESSURE: 58psi/4.0kg/cm² MAXIMUM OPERATING WATER TEMPERATURE: ≤50°C MAXIMUM TESTING PRESSURE: 86psi/6.0kg/cm²

HORIZONTAL SAND FILTERS

POOL FILTERS

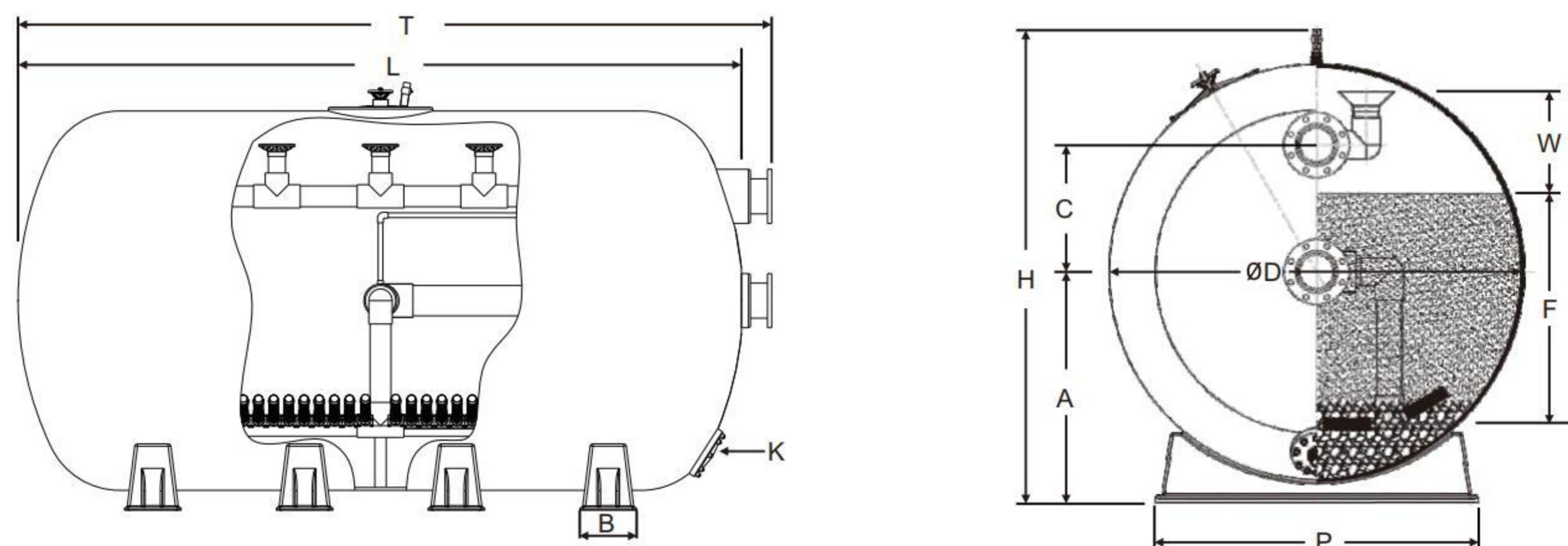

L (mm)	H (mm)	A (mm)	B (mm)	C (mm)	T (mm)	P (mm)	K(mm)	W(mm)	F(mm)
Φ1200mm									
1900	1390	725	250	340	2050	900	180	225	550
2300	1390	725	250	340	2450	900	180	225	550
2500	1390	725	250	340	2650	900	180	225	550
2700	1390	725	250	340	2850	900	180	225	550
3000	1390	725	250	340	3150	900	180	225	550
Φ1400mm									
1900	1600	810	300	400	2150	960	180	225	750
2500	1600	810	300	400	2650	960	180	225	750
3000	1600	810	300	400	3150	960	180	225	750
Φ1600mm									
1900	1830	925	300	450	2100	1230	180	250	910
2500	1830	925	300	450	2700	1230	180	250	910
3000	1830	925	300	450	3200	1230	180	250	910
Φ1800mm									
2500	2050	1040	300	550	2700	1380	180	300	1000
3000	2050	1040	300	550	3200	1380	180	300	1000
3500	2050	1040	300	550	3700	1380	180	300	1000
Φ2000mm									
2500	2220	1090	330	550	2730	1500	180	400	1000-1200
3000	2220	1090	330	550	3230	1500	180	400	1000-1200
3500	2220	1090	330	550	3730	1500	180	400	1000-1200
4000	2220	1090	330	550	4230	1500	180	400	1000-1200
4500	2220	1090	330	550	4730	1500	180	400	1000-1200

CONVERTIBLE CARTRIDGE & DIATOMACEOUS EARTH FILTER

POOL FILTERS



- UV inhibited filament wound structural fiberglass tanks.
- 2" or 63mm Inlet/Outlet PVC unions.
- Either 6 way Multiport or Push-Pull valve available for DE models.
- Easy removal or installation of cartridges or DE elements.
- Cartridges in 20.9, 23.2, 35.3, 41.8 Sq.m² sizes, fully convertible to DE.
- DE elements in 3.25, 4.18, 6.97, 8.39 Sq.m². sizes, fully convertible to Cartridges.
- Large clear lock ring sealed lid for easy interior viewing and media installation/removal.
- Exclusive integral Inlet/Outlet manifold eliminates conventional bulkhead fittings.
- Hose bib drain valve allows removal of tank debris away from mechanical area.

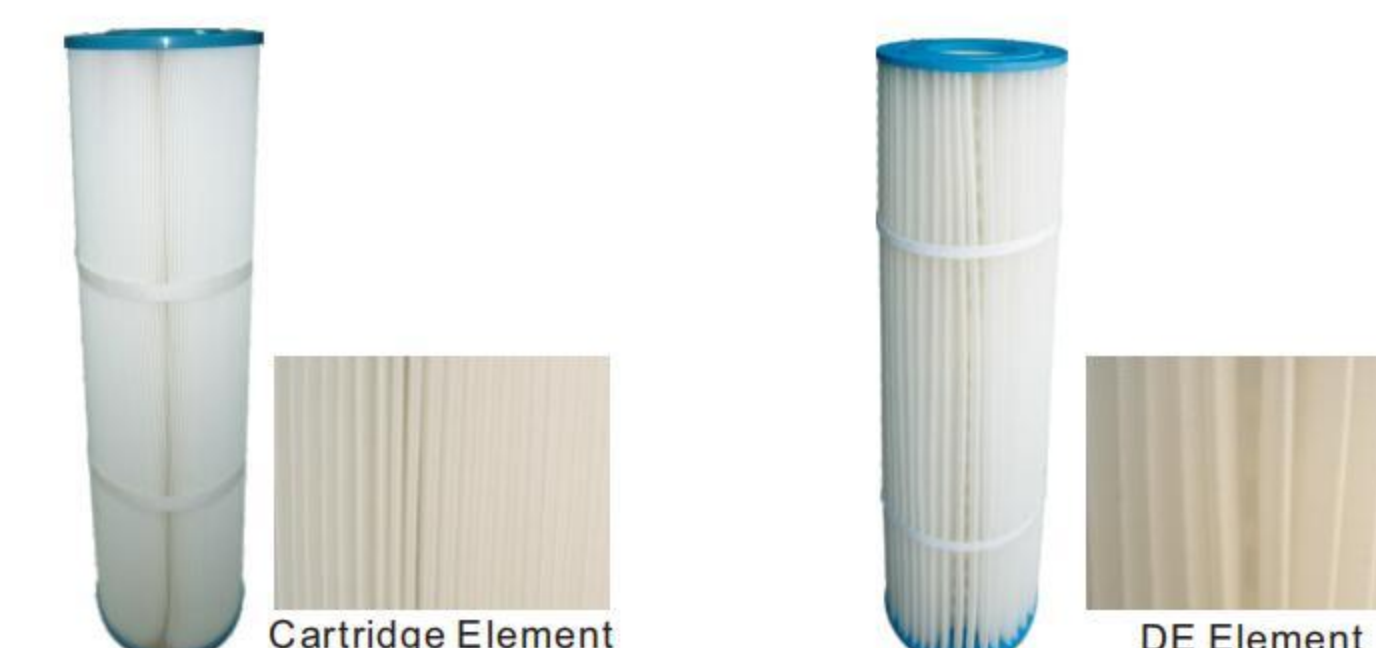
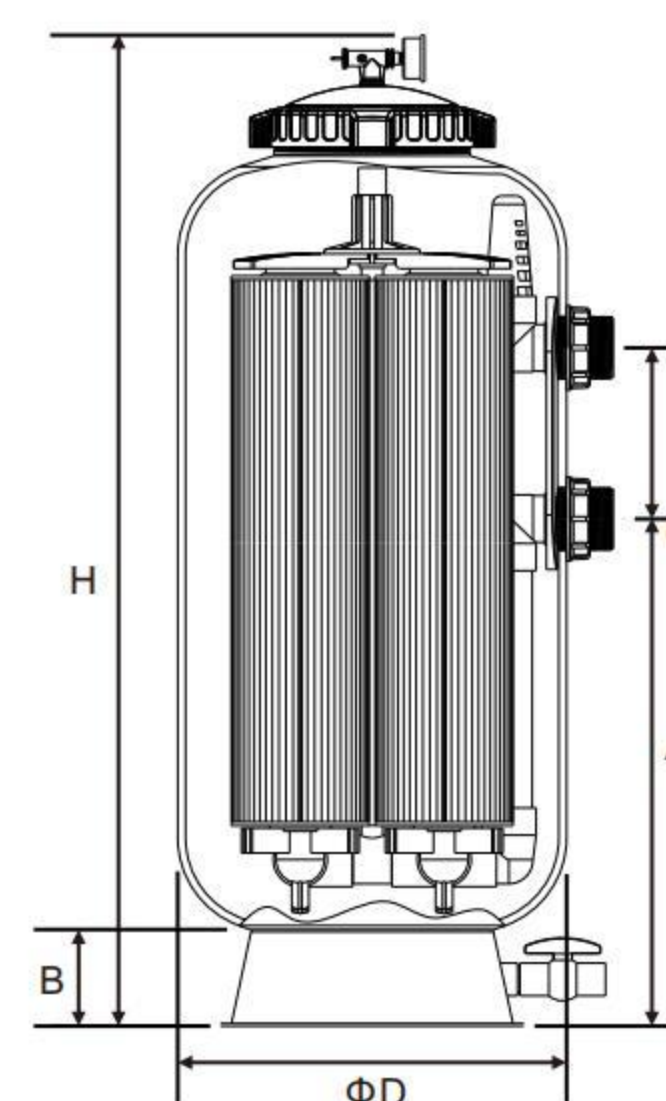

Model	BZX225		BZX250		BZX350		BZX450		BZX520
	BDE35	BDE45	BDE75	BDE90	BDE75	BDE90	BDE90		
ΦD(mm)	500	500	500	500	500	500	500	500	
H(mm)	965	965	1270	1270	1270	1270	1270	1270	
A(mm)	341	341	646	646	646	646	646	646	
B(mm)	125	125	125	125	125	125	125	125	
C(mm)	220	220	220	220	220	220	220	220	

Model	Pipe Size		Filtration area		Design flow		Diatomite weight (kg)	Tank Diameter (mm)	Tank Height (mm)
	inches	mm	m ²	Ft ²	m ³ /h	lpm			
BZX225	2	63	20.9	225	19.08	318	-	500	965
BZX250	2	63	23.2	250	21.35	356	-	500	965
BZX350	2	63	35.3	380	32.30	538	-	500	1270
BZX450	2	63	41.8	450	34.07	568	-	500	1270
BZX520	2	63	44.8	482	36.50	608	-	500	1270
BDE35	2	63	3.25	35	15.90	265	1.59	500	965
BDE45	2	63	4.18	45	20.44	341	2.04	500	965
BDE75	2	63	6.97	75	34.07	568	3.40	500	1270
BDE90	2	63	8.36	90	41.80	696	4.08	500	1270

MAXIMUM WORKING PRESSURE: 36psi/2.5bar/cm², MAXIMUM TEMPERATURE ≤50°C, MAXIMUM TESTING PRESSURE: 58psi/4.0bar/cm²

DIATOMACEOUS EARTH FIBREGLASS FILTERS

POOL FILTERS

D.E. is historically the media of choice for the designers of some of the largest and most beautiful pools in the world, it is now more practical for all backyard pools as well. It brings you the proven performance of diatomaceous earth media in the world's safest and easiest-to-operate filter.

The greater cycle times and minimized maintenance of the filter, coupled with superior grid system, gives you the finest D.E. filter available.

- Good and crude media for filtration--Diatomaceous(D.E.)
- High Filter precision, can reach 2 ~ 3µm.
- Shorter time to backwash, save water and energy sources.
- "Deep bed" designed, save area.



DE650-DE700

DE800-DE1800

With Valve

With Flange

Work Flow

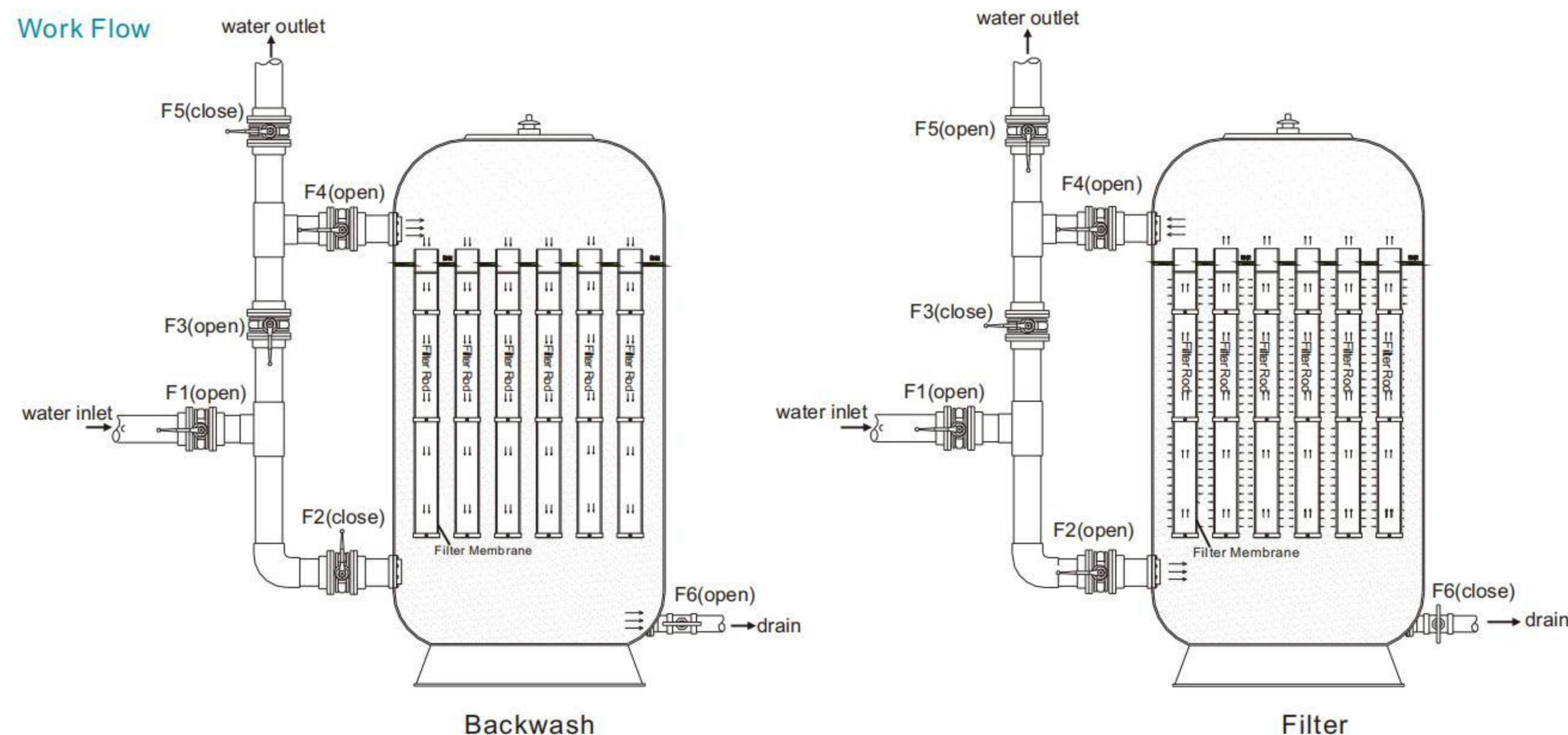

- ◆ Standard: Maximum Working Pressure 250kpa/36psi/2.5bar
- ◆ Optional: Maximum Working Pressure 400kpa/58psi/4.0bar
- ◆ Maximum Temperature 50°C

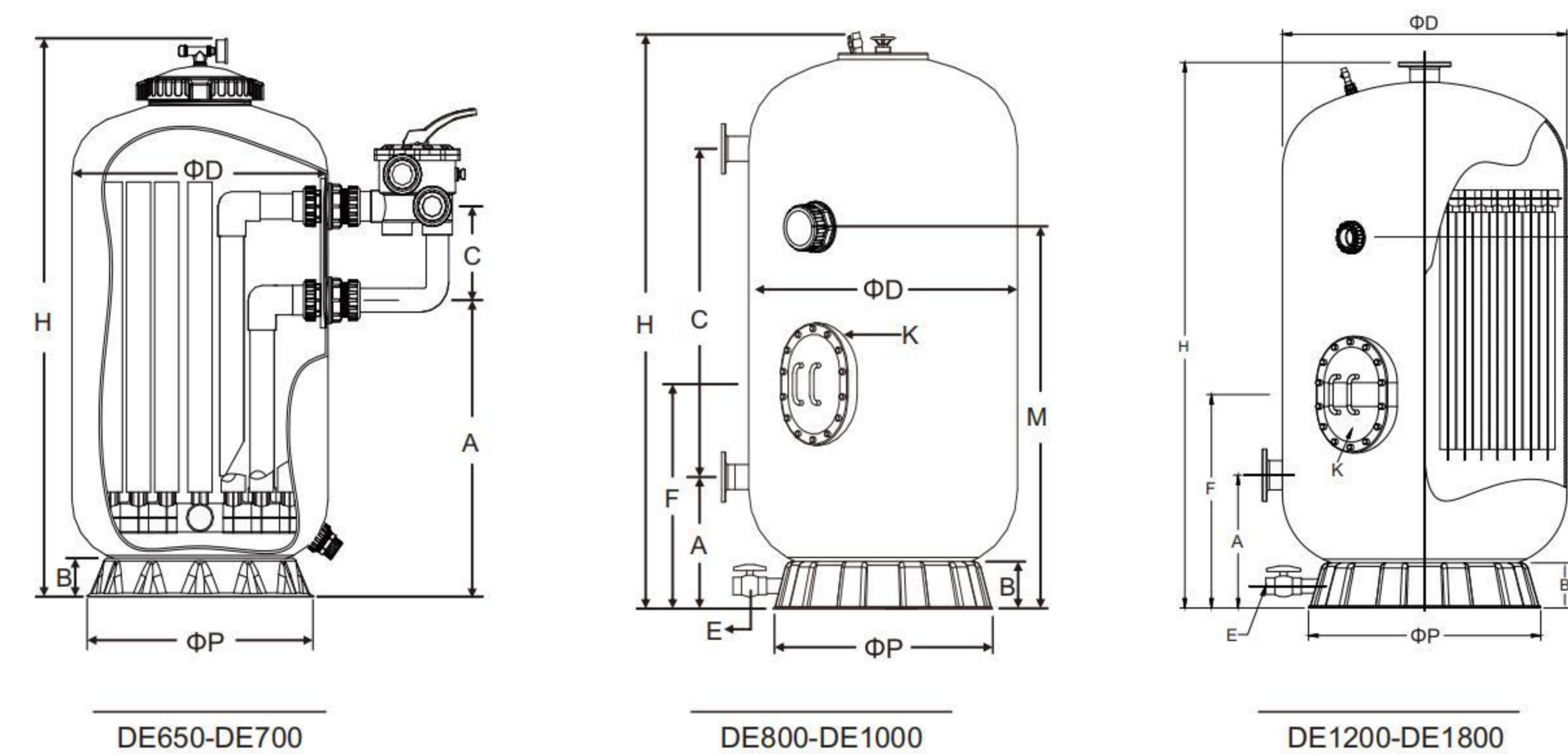

DE650-DE700

DE800-DE1000

DE1200-DE1800

ΦD(mm)	635	700	800	900	1000	1200	1400	1600	1800
H(mm)	1310	1340	2100	2100	2100	2300	2350	2350	2450
A(mm)	700	730	400	400	400	500	600	600	650
B(mm)	95	95	115	115	140	165	165	215	215
C(mm)	220	220	1300	1300	1300	—	—	—	—
E(mm)	—	—	50	50	50	50	63	63	63
F(mm)	—	—	900	900	900	900	900	900	1000
K(mm)	—	—	400X300	400X300	400X300	400X300	400X300	400X300	400X300
M(mm)	—	—	1350	1350	1350	1400	1400	1400	1450
ΦP(mm)	565	565	690	760	830	980	1215	1450	1610

Model	Pipe Size		Filter Area		Design Flow		Required D.E (kg)	Tank Diameter (mm)	Tank Height (mm)
	inches	mm	m ²	Ft ²	m ³ /h	lpm			
WL-DE650	2	63	3.64	39	18	300	2.2	635	1310
WL-DE700	2	63	5.07	55	25	417	3.0	700	1340

Model	Flange Connections	Filter Area		Design Flow		Required D.E (kg)	Tank Diameter (mm)	Tank Height (mm)
		m ²	Ft ²	m ³ /h	lpm			
WL-DE800	90	9.40	101	47	783	5.0	800	2100
WL-DE900	90	11.00	118	55	916	6.0	900	2100
WL-DE1000	110	15.00	161	75	1250	8.0	1000	2100
WL-DE1200	110	23.40	252	117	1949	13.0	1200	2300
WL-DE1400	160	32.60	351	163	2716	19.0	1400	2350
WL-DE1600	160	40.60	437	203	3382	22.0	1600	2350
WL-DE1800	200	53.40	575	267	4448	30.0	1800	2450

POOL FILTERS

HIGH PRESSURE FIBERGLASS FILTERS

POOL FILTERS

- High-performance material satisfies customers' different application
- Apply to water feeding and sewage water treatment, chemical, electronic, petroleum, food etc.
- Φ150mm-Φ900mm filters are made of PE blow molding inner tank with fiberglass.
- Φ1000mm-Φ1500mm filters are made of PE rotational molding innertank with fiberglass.
- Above Φ700 filters are specially equipped with destruction of negative pressure device.
- Strong ability of pressure-bearing

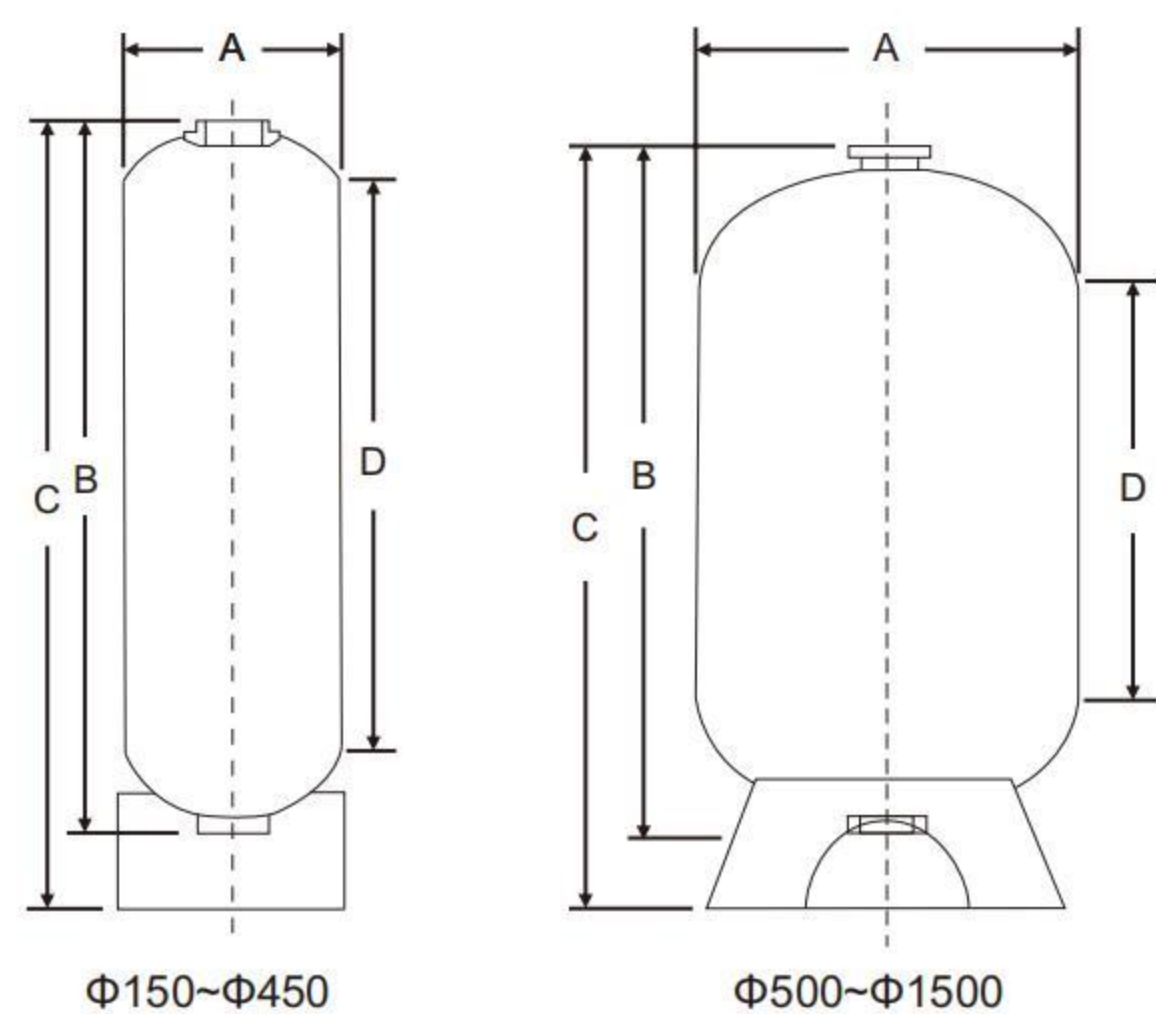

Model	Volume(L)	Top opening	Bottom opening	Diameter (mm)	Filter height (mm)	A(mm)	B(mm)	C(mm)
WL-HA2045	11.5	2.5"-8NPSM	/	200	450	200	430	450
WL-HA2090	24.8	2.5"-8NPSM	/	200	900	200	805	900
WL-HA2011	35	2.5"-8NPSM	/	200	1100	200	1070	1100
WL-HA2590	38.4	2.5"-8NPSM	/	250	900	250	855	900
WL-HA2514	50	2.5"-8NPSM	/	250	1400	250	1430	1400
WL-HA3014	70	2.5"-8NPSM	/	300	1450	300	1430	1450
WL-HA3016	100	2.5"-8NPSM	/	300	1650	300	1630	1650
WL-HA3516	130	2.5"-8NPSM	/	350	1650	350	1630	1650
WL-HA4016	180	4"-8UN	/	400	1650	400	1630	1650
WL-HA4516	185	4"-8UN	/	400	1650	450	1620	1650
WL-HA5018	280	4"-8UN	4"-8UN	500	1800	500	1650	1800
WL-HA6018	400	4"-8UN	4"-8UN	600	1850	600	1650	1850
WL-HA6020	460	4"-8UN	4"-8UN	600	2000	600	1850	2000
WL-HA7518	650	4"-8UN	4"-8UN	750	1850	750	1620	1850
WL-HA7520	700	4"-8UN	4"-8UN	750	2000	750	1850	2000
WL-HA9020	1040	4"-8UN	4"-8UN	900	2000	900	1950	2000
WL-HA9024	1170	4"-8UN	4"-8UN	900	2400	900	2030	2400
WL-HA10018	1040	4"-8UN	4"-8UN	1000	1850	1000	1650	1850
WL-HA10024	1332	4"-8UN	4"-8UN	1000	2400	1000	2030	2400
WL-HA12024	1909	6" Flange	6" Flange	1200	2400	1200	2000	2400
WL-HA15024	2588	6" Flange	6" Flange	1500	2400	1500	2000	2400

Maximum Working Pressure: 600kpa/87psi/6.0bar Factory Testing Pressure: 900kpa/130psi/9.0bar Maximum Temperature: ≤49°C
Max Vacuum: 127mmHg Filtration Media: silica sand, activated carbon, etc

BIOLOGICAL FILTER

POOL FILTERS

Bead filter are closed pressure filter containing food grade polyethylene granules or beads. The form and size of the beads create a large surface on which bacteria and suspended solid can attached it. It provides mechanical and biological filtration at a single unit which compete with bobbin wound filter, 6-way multiport valve, pipings, circulation pump, air blower, control box and base. It has been engineered uniquely for pond and aquarium.



Model	BFG 450	BFG 500	BFG 650	BFG 700	BFG 800	BFG 900	BFG 1200
ΦD (mm)	450	500	630	700	800	900	1200
A (mm)	660	730	790	885	1020	1110	1350
B (mm)	385	405	435	520	605	650	820
C (mm)	260	280	310	300	385	430	600
E (mm)	385	405	435	480	600	650	820
ΦP (mm)	390	390	565	565	790	790	1010

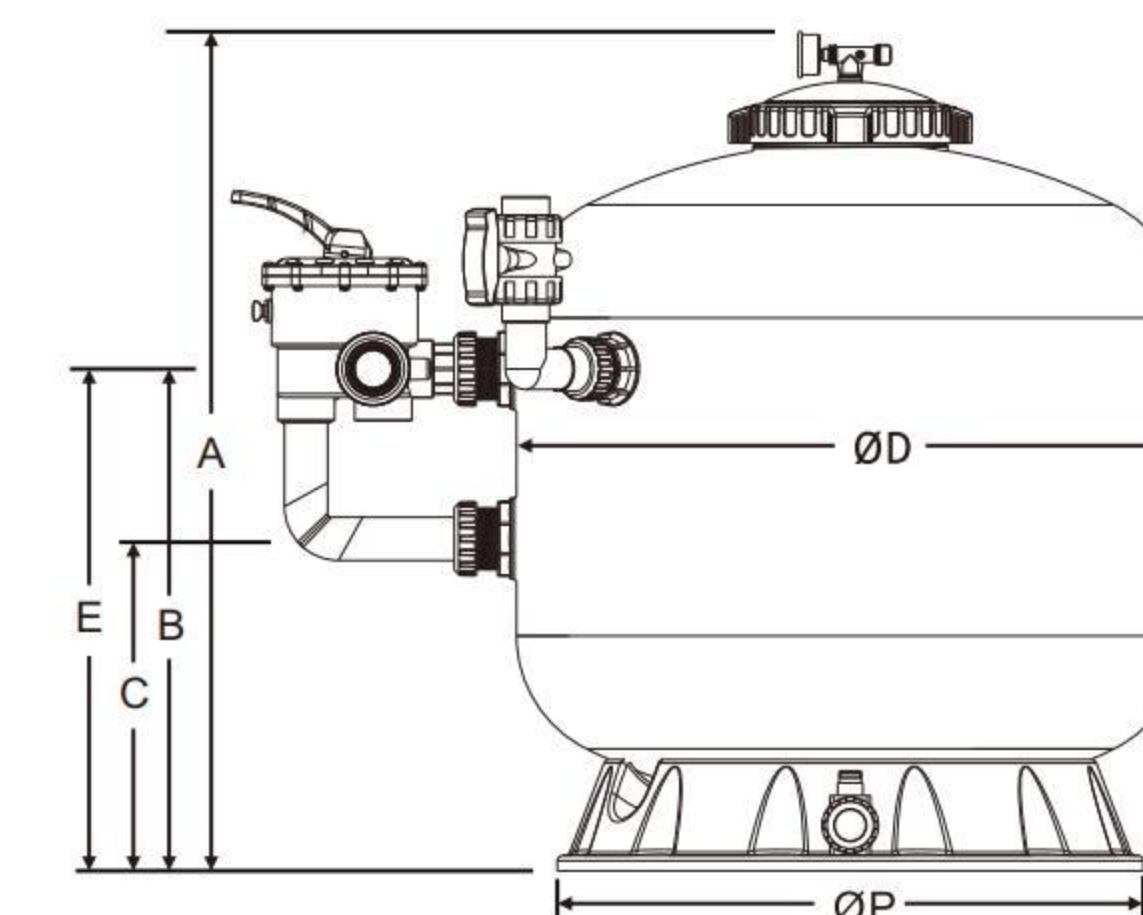

Model	Design Flow		Pond Size (m³)	Fish Load (kg)	Blower (watt)	Media (kg)	Filter Diameter (mm)	Filter Height (mm)
	m³/h	lpm						
WL-BFG450	8	133	6	20	700	18	450	660
WL-BFG500	11	183	10	35	700	30	500	730
WL-BFG650	16	267	30	78	900	50	650	745
WL-BFG700	19	317	34	94	900	75	700	830
WL-BFG800	25	417	52	124	900	100	800	905
WL-BFG900	30	500	73	172	1000	125	900	1005
WL-BFG1200	42	700	148	310	2*1000	325	1200	1325

MULTIPOINT VALVES

POOL FILTERS

POOL FILTERS

6-WAY MULTIPOINT VALVE

New type of multipoint control valve, made of ABS and engineered for maximum flow at lower pressure drops will be the first choice in the same ones. All the valves feature an easy-to-easy lever action handle that lets you "dial" up to six valve/filter functions : filter, backwash, waste, rinse, closed or recirculate. Complete with an integral sight glass that lets you see when the backwashing cycle is completed, our wide selection of valve configurations allows you to the proper application: residential and commercial.



1.5" Multipoint valve for top mounted clamp lock filter



2" Multipoint valve for top mounted filter



1.5" Multipoint valve for side mounted filter



2" Multipoint valve for side mounted filter

4-WAY MULTIPOINT VALVE



1.5" Multipoint valve for top mount filter

BUTTERFLY VALVE FOR COMMERCIAL FILTERS



4-Way Valve Manifold
Size: 3"- 8"



5-Way Valve Manifold
Size: 3"- 8"

DE FILTER TOP MANIFOLD WITH BUILT IN AIR RELIEF VENT

- Heavy-duty materials
- Top manifold with built in air relief vent
- Manufactured to the highest standards to provide you with a quality product
- Suitable to use with only one rod



DKC2021

Built-in air relief vent

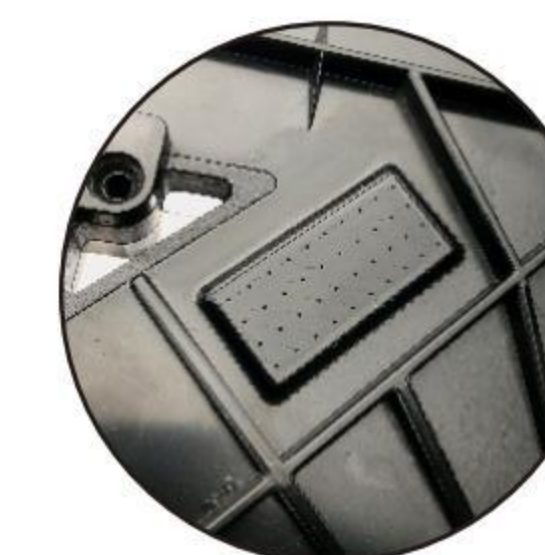

DE FILTER SPIDER BOTTOM MANIFOLD

- Heavy-duty materials
- Manufactured to the highest standards to provide you with a quality product

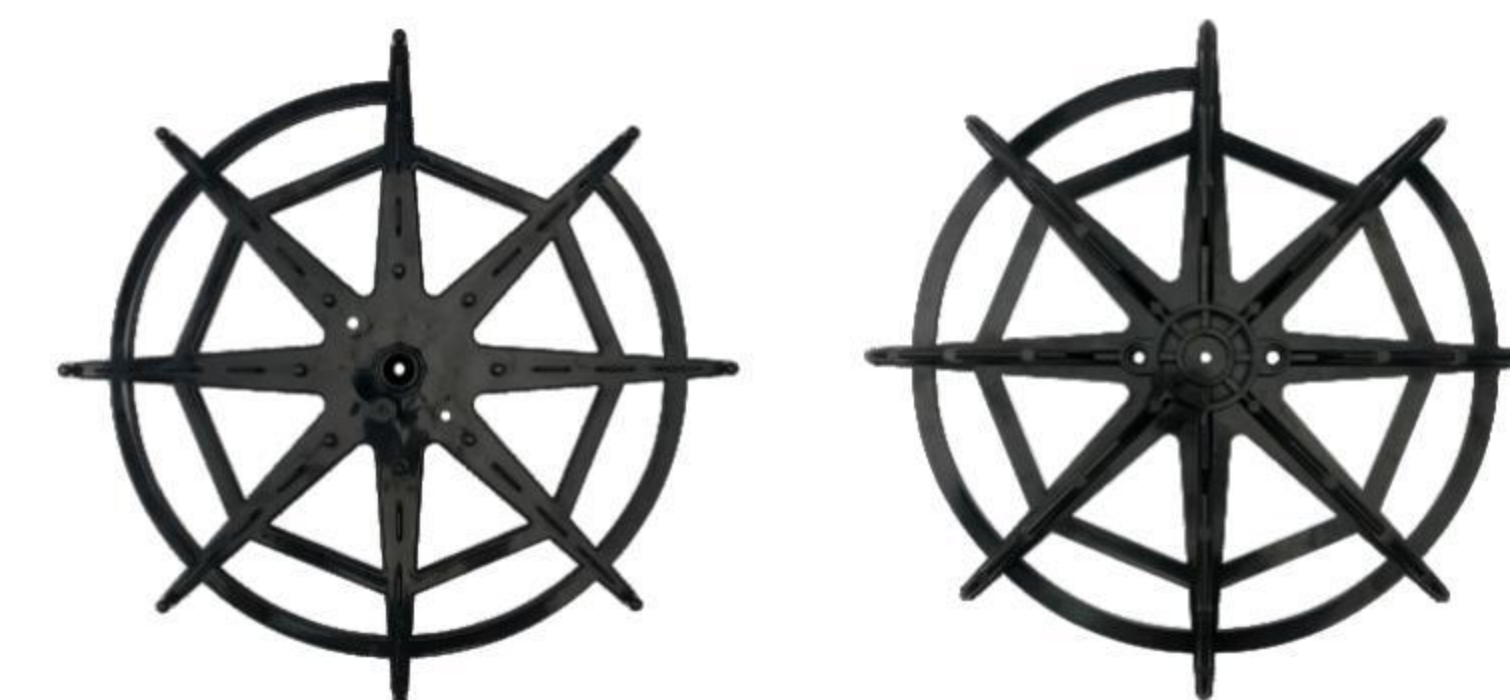

DKC2021B